

**APOLLO**

USER MANUAL

USA

**apolloscooters.co**

CANADA

**apolloscooters.ca**

**PRO**

# INTRODUCTION

## Hello World

Thank you for purchasing the Apollo City. The electric scooter industry is still young and it takes forward-thinking customers like yourself to advance it. We hope you enjoy your new scooter as much as we loved developing it.

Please be aware that the model depicted in this manual serves as a general representation. Your specific model may feature slight differences in design or functionality. For the most accurate and current user manual, please visit our Servicing & Support Centre to access the latest version.

## How to get help?

We're here to help regardless of the issue you are facing. Visit our Support Page below to access our Servicing & Support Center, as well as to find various ways to get in touch with our team.



### **⚠ WARNING**

Incorrect assembly, maintenance, or use of your Apollo scooter can cause component or performance failure, loss of control, serious injury, or death. Even if you're an experienced scooter rider, you must read and understand the entire manual and any documentation provided for subcomponents or accessories before riding. In the event of a malfunction or damage to any of the components during set up or use, please discontinue set up or use and contact our support team through our Support Page. If you are not sure you have the experience, skills, and tools to correctly perform all assembly steps in the manual and the assembly video, consult our support team or a local electric scooter shop.

For your safety and that of others, please read and make sure you understand all of the warnings and instructions contained in this Manual. FAILURE TO FOLLOW THESE WARNINGS AND INSTRUCTIONS CAN RESULT IN SERIOUS INJURY OR DEATH.

## Table of Contents

Unboxing.....	5
Assembly .....	6
Operation .....	10
Settings .....	16
Battery Information .....	17
General Safety .....	18
Maintenance .....	20
Screw List .....	26
Troubleshooting .....	30
Maintenance Table .....	31
Warranty .....	32
FCC Statement .....	34



# UNBOXING

## **⚠ WARNING**

Improper assembly of your Apollo scooter can cause component or performance failure resulting in loss of control, serious injury, or death. In the event of a malfunction or any damage to any of the components during set up of your scooter, please discontinue set up immediately, do not ride the scooter, and contact our support team. If you are not sure you have the experience, skills, and tools to correctly perform all assembly steps in the manual and the assembly video, consult our support team or a local electric scooter shop.

## **Intro**

Setting up your scooter right is the single most important step to your safety.

Please note that this process is also available in video format through our Servicing & Support Center.

We recommend having the following items ready prior to starting the setup process:

- Box cutters or knife
- Stool or bench
- Air pump
- Someone to help

## **Unbox your scooter**

Open the box using the box cutter and fold open the top. Inside you should see protective styrofoam along with the following contents:

- Apollo City electric scooter
- Manual
- Charger and cable
- Hex key
- Screw Kit

If any of these items are missing, please contact us immediately.

With the help of someone, remove the scooter from the box and place it on a flat surface. We recommend using a stool or bench as the wheels need to be able to spin freely. Carefully remove the protective material from the scooter and set it aside. We require you to keep both the styrofoam and the box in case you need to ship your scooter back to us. Otherwise recycle the materials wherever possible.

# Prepare for assembly

## Unfolding

- 1 The first step is to unfold your Apollo Pro.
- 2 Unfold the stem by pulling it to a vertical position. Ensure you do so until the stem is completely vertical.
- 3 Locate the folding latch and bring it up, locking the stem. The latch will require some force to lock fully upright.
- 4 Lastly, make sure the safety button of the folding mechanism is clipped in the stem. This safety mechanism prevents the latch from unlocking due to vibration or shock. If the stem is locked into the main body, press on the unlock button shown by the big arrow and pull up on the stem. Pull up on the stem and follow steps 2 to 4 to lock the stem in place

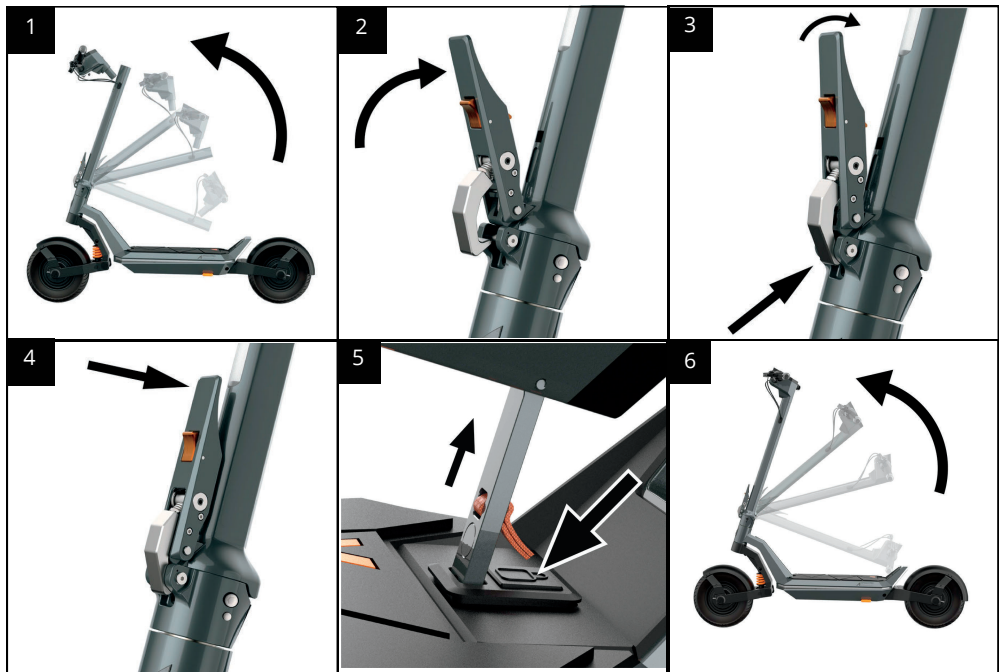

### ⚠ WARNING

Always follow the below instructions when unfolding your scooter and prior to each ride. Failure to ensure the safety button of the folding mechanism is clipped into the scooter stem and to ensure the stem is fully secured before your ride may lead to the stem coming undone during your ride, which can result in loss of control, serious injuries and death. Do not operate the scooter if you notice anything wrong with the scooter stem, the safety button, or the locking mechanism.

## Attach handlebar

- 1 Connect the male connection cable coming out of the handlebar into the female cable coming out of the front stem. Make sure the pins are aligned.
- 2 Make sure the male port and the female port are aligned properly. Insert the handlebar at the top of the front stem and tighten into place with the 4 hex screws provided.
- 3 Caution: Be careful not to damage the cable when connecting the handlebar to the front stem.
- 4 You will find that the latches and buttons on your handlebar are not tight. We deliver this way to avoid damage during shipping. Before tightening the screws, adjust the left button panel. Twist it upward or downward until it reaches a comfortable angle, keep in mind that once on a scooter, you will be higher up than you are while setting up your scooter. When you have found a comfortable position, go ahead and tighten the screws.
- 5 Repeat the same process for the screws on the right hand side of your handlebar.

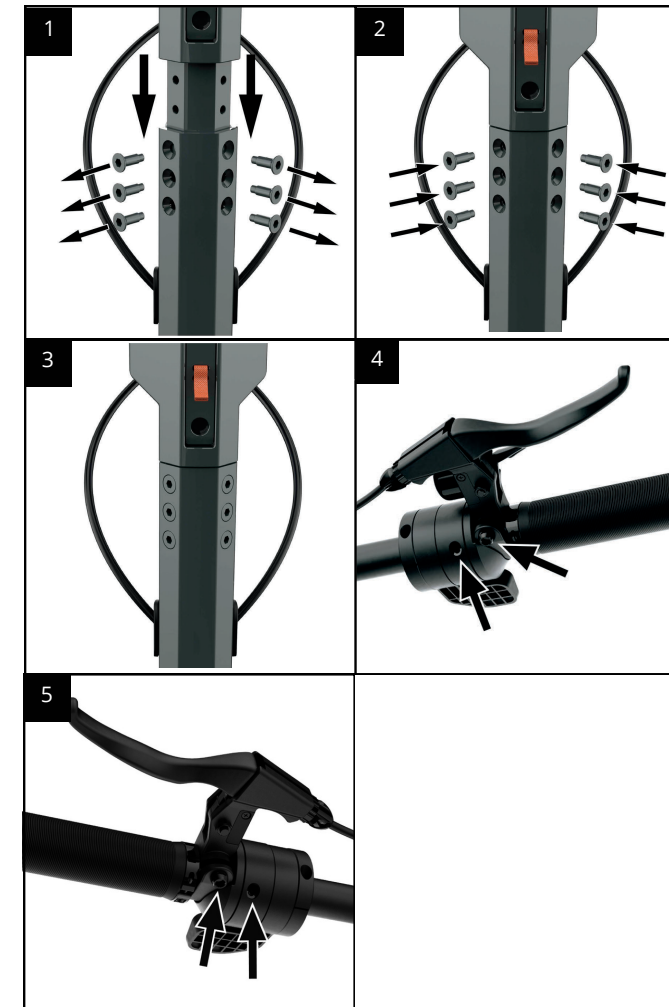

## Perform test

**1** Locate the power button on the right side of the handlebar and press it for 3 seconds to power on the scooter. You should now be able to see the display powered on. Keep the scooter elevated on the stool or bench, as the testing will involve spinning both wheels. The scooter should be in Kick to Start mode, to begin testing the motors, spin the wheel manually and then press the throttle. The wheels should begin to spin normally. You may notice either motor emitting a noise at low speeds, this is normal. The motor is communicating with

the controller and identifying its position as well as which direction to roll in. If after performing this test the wheels are spinning normally, you can now move to step 2.

### **⚠ WARNING**

If you notice one of the motors is not spinning DO NOT ATTEMPT TO OPERATE THE SCOOTER. Contact us immediately.

**2** Begin by testing your brakes. Press the throttle on the right side of your handlebar and notice the motor wheels start to accelerate. Continue to accelerate for 5 seconds, then release the throttle and slam both brakes at the same time. The wheels should stop immediately.

**3** Test gear change by pressing the Power Button quickly twice. Two short clicks will cycle through the speed levels.

- Eco mode
- Comfort mode
- Sport mode

To go into Ludo press the power button quickly three times. To read more about the speed of each mode, refer to the Display section in this manual.

**4** Next, to turn on the lights quickly once. Confirm all of the lights power on: headlight and one rear tail light.

**5** Next, test the horn by pressing once on the mode button.

### **⚠ WARNING**

If all of the lights do not power on, DO NOT ATTEMPT TO OPERATE THE SCOOTER. Contact us immediately.

**6** Test your right and left signals. Start by testing your right signal by pressing the button with an arrow on the right side of your handle bar. Your right signals should turn on. To turn them off, click on the button again.

**7** Test your left signals, press the arrow button on the left side of the handle bar. Your signals should turn on. To turn them off, click on the button again.

**8** Next, grab an air pump and locate the air valve on the front tire. Remove the safety cap and attach the pump tube to the tire valve. Turn on the air pump and read the PSI measure - the ideal tire pressure for the Pro is 35PSI.

**9** Inflate or deflate the tire as needed until the pressure is 35PSI. Repeat the step with the rear tire.

Congratulations, you have successfully set up your new Apollo Pro.

If you experience difficulties with the setup at any step, please refer to our Servicing & Support Center for a video walk-through of the process. Alternatively, you can contact our support team via our Support Page.

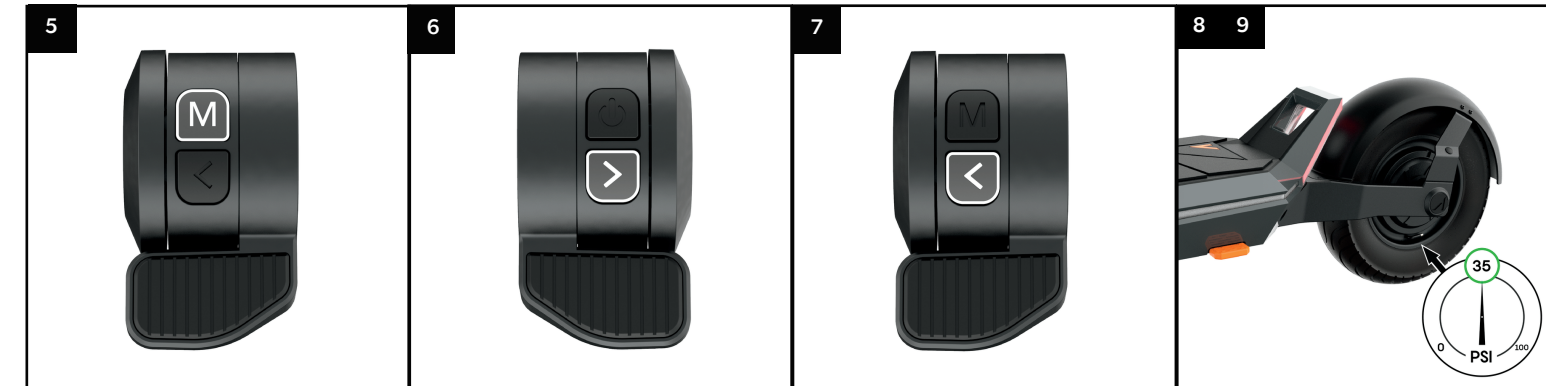
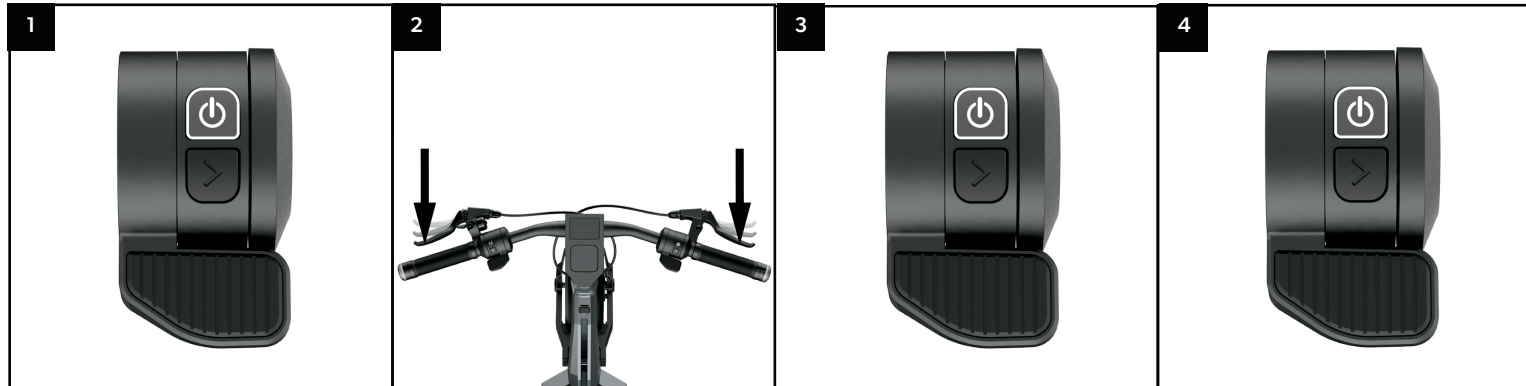

# OPERATION

## Charging

This section focuses on how to charge your scooter correctly. For information about battery health and best practices, please review the Battery Information section.

The battery pack comes with a built-in battery management system. This includes overcharging protection amongst other features, allowing your scooter to stay plugged in even after it is fully charged.

Please note that this applies to short periods of overcharging, such as the scooter being plugged in overnight. Please do not leave the scooter plugged in and charging for extended periods of time as it may result in battery damage or fire.

### NOTICE

You will need to turn off the scooter before charging.

- 1 First, ensure the two parts of the charger are connected securely. The wall AC plug should be connected to the charger box. The connection between the cable and box should feel firm with no wobble or play.
- 2 Next, locate the charging port cap on your scooter and open it to find the charging port. Locate the round connector on one end of the charger, this is the end you must insert in the charging port.
- 3 Gently insert the cable.
- 4 Proceed to plug the AC plug on the other end of the charger into a 120 volt power outlet. If the battery is 100% full, the charger light will turn green. If the battery is not fully charged, the charger light will light up red.

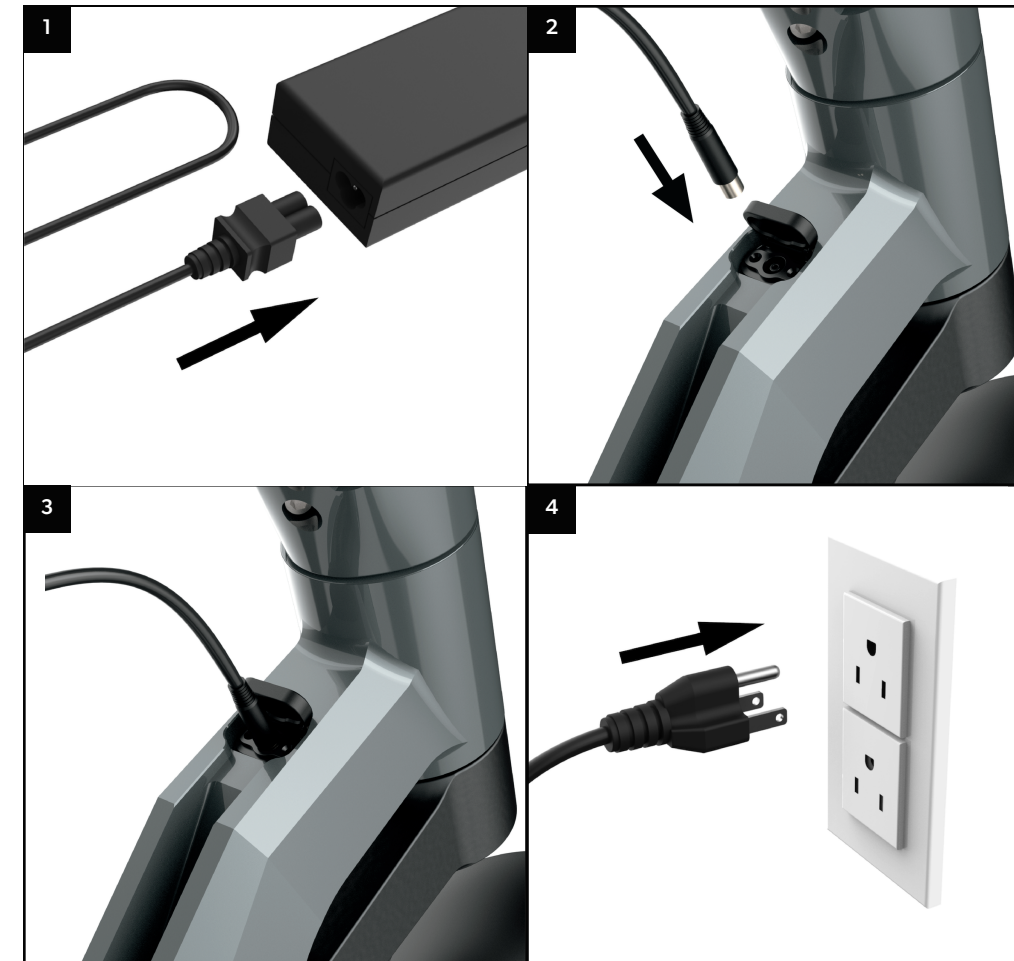

## Throttle

The Apollo Pro comes equipped with two thumb throttles, one on each side of the handlebar for ease of use. The left hand side throttle is the regenerative brake, the right hand side throttle is for acceleration.

The acceleration throttle is designed to be progressive - this means that a soft press on the throttle will exert proportionately little acceleration. Full pressure on the throttle will trigger maximum output and therefore peak acceleration.

### WARNING

Never press the throttle when walking with your scooter. Pressing the throttle while walking the scooter may cause loss of control, and serious injury or death to you or others.

## How to brake

The Apollo Pro has two different types of brakes. The regen brake which allows you to capture energy from braking and recharge your battery, and the dual drum brake.

The regen brake will allow you to have a smoother and more efficient stop. To use it, press on the left hand side thumb throttle. To control how smooth or abrupt your scooter comes to a stop log in to your Apollo App and adjust the brake preferences. The regen throttle is designed to be progressive - this means that a soft press on the throttle will exert proportionately little braking power. Full pressure on the throttle will trigger maximum output and therefore peak braking power. For more information about the Apollo App refer to the App section in this manual.

### Braking for the first time:

Before taking your scooter for a ride, we recommend for you to adjust the regen brake in your Apollo App. Refer to the App section in this manual for more information.

### NOTICE

We recommend you not to use the regen brake when the battery is 100% charged. This can cause an overcharged battery and result in damage to the controller or the battery. You should only start using the regen brake when the battery is at 90% charge level or less.

Additionally, keep in mind that using the regen brake for long periods of time (for example a long downward hill) can generate a lot of heat and have a negative impact on the controller. We recommend using the regen brake only for short period of time.

## Folding

- 1 To fold, begin by locating the safety button and press it to unlock the folding lever.
- 2 Grab the folding latch, and pull it down to fold the stem. Make sure to keep one hand on the stem at all times as it will drop down instantly after the folding latch is released.
- 3 Pull it down until you feel the latch is fully open.
- 4 Fold down the stem towards the foot stand.
- 5 Make sure it is folded all the way down before moving on to the next step.
- 6 Unfold the tab located on the headset.
- 7 Proceed by gently lowering the stem until the tab can be inserted in the main body.

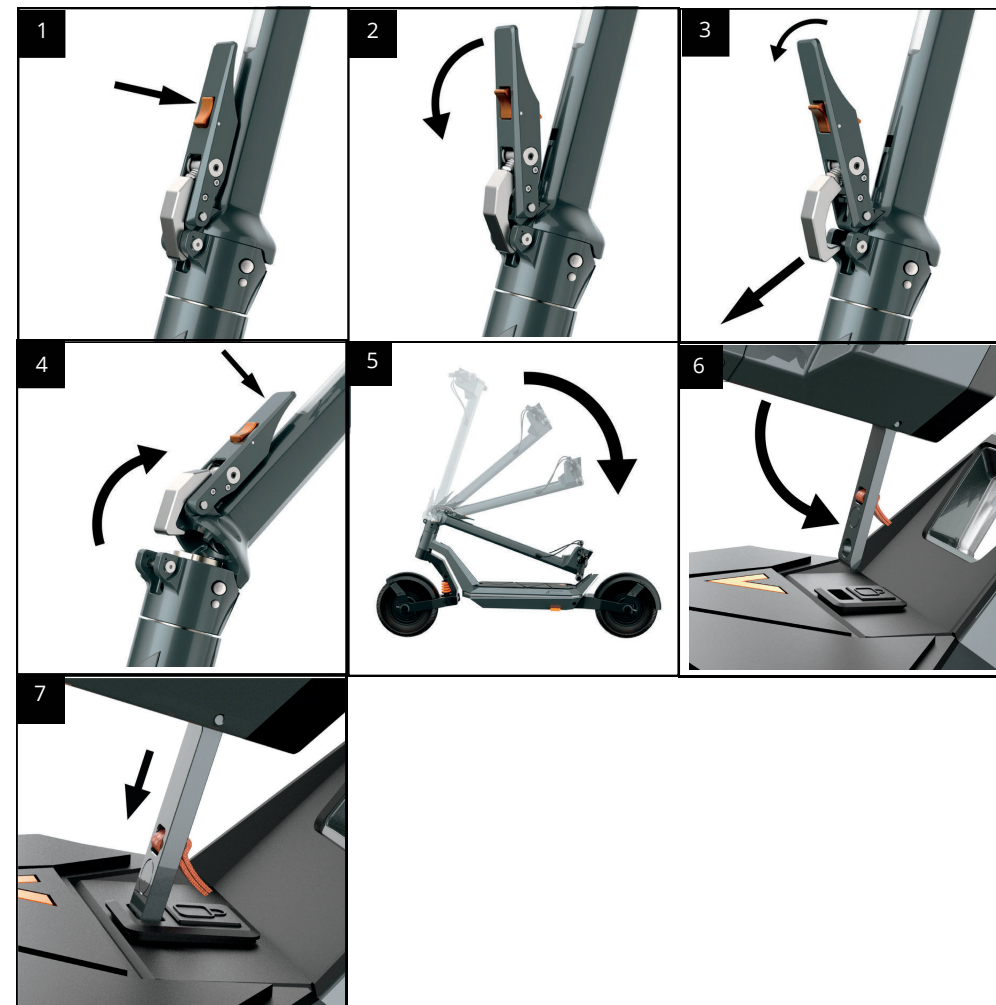

## Handlebar features

- 1 Display
- 2 Accelerator throttle (right-hand side of the handlebar)
- 3 Accelerator throttle - Power button - light on/off - Gear change
- 4 Accelerator throttle- right turning signal
- 5 E-brake throttle (left side of the handlebar)
- 6 E-brake throttle- Mode button-horn
- 7 E-brake throttle- left turning signal

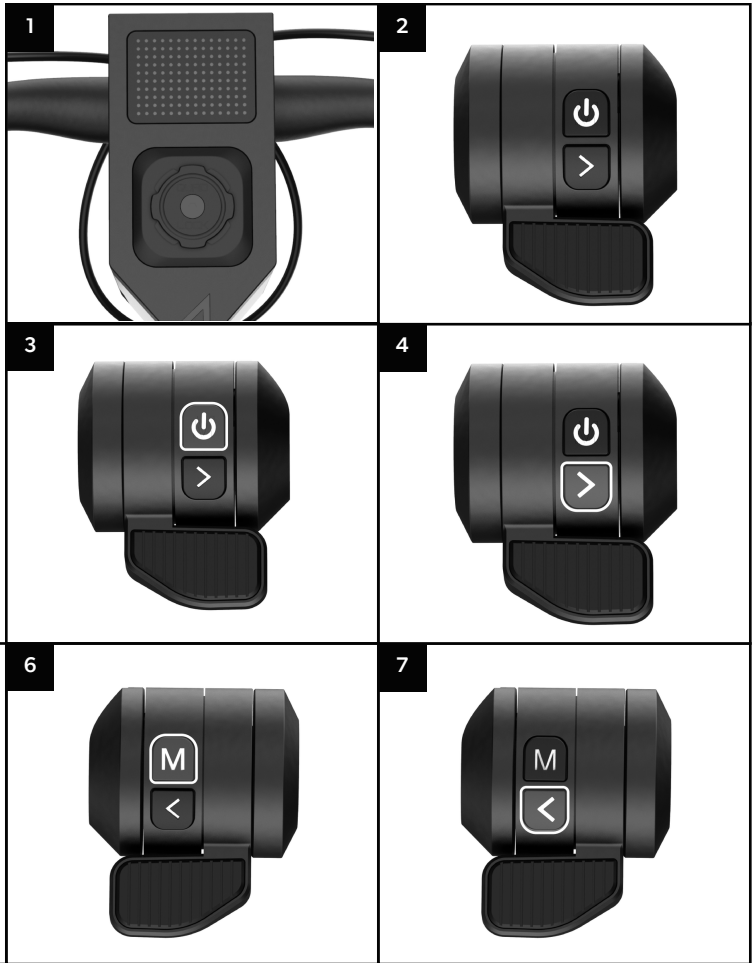

## DISPLAY

The display screen, located on the handlebar, shows you the speed, the battery charge and any failure displays.

The scooter is controlled by three buttons:

### POWER BUTTON

- 1. One long click — On / Off
- 2. One short click — turn on/off light
- 3. Speedometer
- 4. Double click - Gear Change (Cycle from 1-2-3)
- 5. Triple Click - Enter Ludo mode

### TURN SIGNALS

- 6. Left arrow short click — Left turning signal
- 7. Right arrow short click — Right turning signal

### MODE BUTTON (M)

One Short click — Bell/Horn  
(Not shown on display)

While riding you may notice an occasional beeping noise, indicating you are riding above the speed of the selected gear. (Not shown on display)

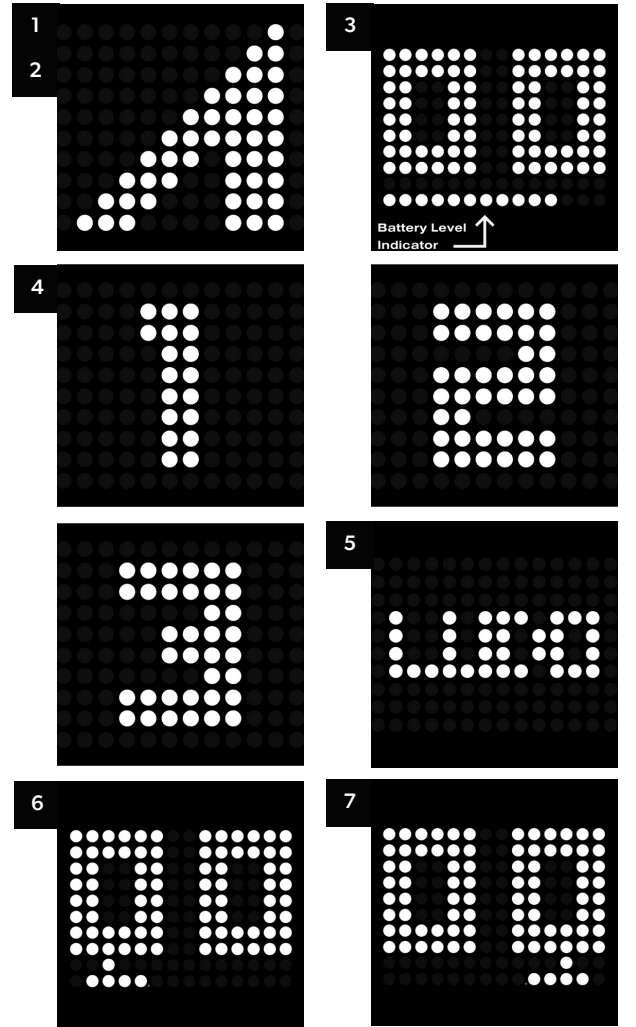



# SETTINGS

## App

You can manage your settings through the Apollo App. The settings you can manage through your App are:

- Control Gear
- Control Speed Metrics (KMH/MPH)
- Control top speed limit
- Control acceleration and regen brake
- Control ON/Off cruise control
- Control the time it takes for the cruise control to turn on
- Control KickStart On/Off mode

\* The settings you can control via the Apollo App may change with future App updates.

The Apollo App is available for iOS and Android. To download it, visit our website - [Apolloscoters.co](http://Apolloscoters.co) - or look for it in your APP store as Apollo Scooters.

You can also download it using the following QR code:



To use the App, follow the steps indicated in the App. App updates may be rolled out at any moment to improve the user experience. For any App related issues or for the latest App related information, please reach out to our support team who will provide the latest information.

# BATTERY INFO & LOW BATTERY

## Charging

- Charge the scooter fully after every ride. This will prolong the battery life.
- When charging, wait for the charger light to turn green. The charging process will then be complete and all the cells will have been balanced by the battery management system.
- If not used, power on the scooter once at least once a month to check the charge level. Ideally, the charge level should be between 70% and 90%.

- E-scooter model reference: 5302, A12 PRO
- Charger model reference: SPC-290WW-588045
- Battery model reference: JT-ESB14-01

## Storage

- The storage temperature needs to be between 10°C–25°C / 50°F–77°F
- For long term storage (such as the winter season), the ideal battery level is approximately 70% (50V). This is based on the fact that at 70% charge level, the energy inside the battery cells is the most stable.

### NOTICE

When there is only one battery bar remaining, it is advisable to stop using the scooter if possible and to recharge it in order to prolong the lifespan of the battery, a deep discharge will decrease the lifespan of the battery.

## Improper Storage and Charging Can Lead to Scooter Damage

- Wait 30 minutes after a ride before attempting to charge the battery.
- Do not leave the scooter in cold spaces (such as unheated garages or outdoor sheds).
- Do not leave the battery undercharged for 48 hours or more. This can result in battery damage which is not covered by warranty.
- Do not use chargers that are not sold or approved by Apollo Scooters.
- Keep the battery away from heat or fire, a failure to do so may result in a serious injury or death.
- If there is any damage to the battery, the scooter will not turn after charge or it will not charge. DO NOT ATTEMPT TO OPERATE THE SCOOTER. Contact us immediately.

# SAFE RIDING INSTRUCTIONS & WARNINGS

## ⚠️ WARNING

Apollo Scooters are designed to be used and operated by adults and should not be used by anyone younger than 18 years of age. Should the rider have any disabilities or impairments (visual, hearing, language, seizure, etc), please consult your physician before any ride or purchase of an electric scooter.

You are responsible to perform due diligence, understand and follow all laws, rules and regulations, for the safe and lawful operation of your electric scooter, in the locations in which you choose to operate

it. If not used properly or lawfully, electric scooters can lead to injury or death. By purchasing an Apollo scooter, you assume the responsibility for its safe and lawful operation as well as the risks for any failure to safely and lawfully operate it. Any fines due to illegal or unauthorized use, including but not limited to any failures to wear protective equipment, are your responsibility. Should you have any questions or concerns, feel free to contact us at support@apolloscooters.co

Please read the entire manual carefully. If uncertain about any section, contact us directly or visit our Servicing & Support Center to find more information. We always recommend starting slow and getting used to the scooter before riding at faster speeds and for longer distances.

- ALWAYS wear a helmet when riding.
- ALWAYS inspect your scooter before riding. Do not ride if you notice any damage to your scooter.
- ALWAYS make sure the safety button of the folding mechanism is clipped into the stem and that stem is fully secured before beginning your ride.
- ALWAYS keep both hands on the handlebar when riding.
- ALWAYS ride safely and at an appropriate speed to avoid falls and collisions.
- ALWAYS avoid contact with moving parts of the scooter, such as the motor and wheels.
- NEVER ride under the influence of any drugs, alcohol or substance that could limit or affect judgement, control or rider safety. You must always ride with a fully conscious and sober mind to ensure a safe ride.
- NEVER exceed the maximum capacity weight of the scooter.
- NEVER ride on sidewalks, motorways or highways.
- NEVER ride with more than one rider.
- NEVER ride on stairs, jump the scooter, or operate it at high speeds over bumps for risk of loss of control.
- NEVER race or perform stunts with the scooter.

## Operating in Wet Conditions

### ⚠️ WARNING

In rain, snow, ice, or other wet conditions, braking distances increase and the risk of loss of control increases. Riding in these conditions, and/or failing to take into account increased braking distances, can cause loss of control, serious injury, or death.

Riding your scooter in heavy rain or wet condition may introduce moisture in the main compartment which could damage the scooter's electronics.

### ⚠️ WARNING

Maximum and minimum rider weight: 50~150kg  
Maximum speed: 20 km/h  
Disposal: Handle according to local regulations.

## Protective Gear

### ⚠️ WARNING

We strongly recommend wearing protective equipment any time the scooter is in use. In addition to always wearing a helmet, it is recommended that you also wear other protective gear, including but not limited to, knee and elbow pads, and protective armor.

## Operating in Cold Conditions

### ⚠️ WARNING

Operating in cold conditions could cause condensation and moisture to accumulate in the main compartment which could damage the scooter's electronics.

## Avoid Exposure to Water and Humidity

### NOTICE

You must avoid exposing your scooter to water and humidity. Apollo scooters are not waterproof and are not designed for extreme or prolonged exposure to water or humidity. Operating your scooter in rain, wet, or other extreme (ice, snow, etc.) conditions can cause component or performance failure, in addition to loss of control, serious injury, or death. Please note that any damage to the scooter due to water exposure is not covered by warranty.

# MAINTENANCE



## WARNING

Incorrect assembly, maintenance, or use of your Apollo scooter can cause component or performance failure, loss of control, serious injury, or death.

### NOTE:

This section is available in a video tutorial which can be found on our Servicing & Support Center.

## Getting started

We recommend doing maintenance to your scooter in accordance with the table found on p.31 of this manual to make sure all of the components are working properly. Below you can find the steps to perform a basic maintenance of your Apollo Pro. However, if you need additional information or help, please contact our support team directly via our Support Page.

A tune up consists of the following steps:

- Tire pressure check
- Bearing lubrication
- Suspension lubrication
- Brake adjustment
- Screw tightening

You will need a few things to get these done, all of them can be purchased at a local hardware store. If you have difficulty locating these items, contact our support team for help:

- Electric tire pump/inflator
- Jig-a-loo lubricant (or any other lithium grease in spray format)
- Blue Loctite
- Basic toolkit

These are low cost items that, if used regularly, can make your scooter last dramatically longer. In other words, they're an investment definitely worth making.

## Tire pressure

Let's get started with a tire pressure check, which will allow you to see the tire pressure of your tires. The ideal tire pressure for the Apollo Pro is 35PSI. It is important to keep your tires at the ideal pressure for a better riding experience and to avoid getting a flat tire.

To get started place your scooter on a bench, chair, or box, making sure that the tires are easy to access. Start with the front tire - locate the air valve and remove the safety cap.

Attach the air hose and flip the latch to tighten it. You should be able to power on your electric pump and get a read of the current tire pressure.

If it's below 35PSI, start to inflate until the dial reads exactly 35.

If the pressure is higher than 35PSI, deflate the tire by pressing down on the air valve mechanism. To do so, find a small object such as a pen or key, and insert it into the air valve. You will hear the air escape. Do so until the tire feels flat, then reattach the electric pump and inflate until at 35PSI. When the tire is properly inflated, put the cap back on the air valve.

Repeat the process with the rear tire.

## Bearing lubrication

The next maintenance step is to lubricate the bearings. Your bearings are the connection between the rotating wheels of your scooter and the non-rotating frame that holds them stable. As you use your scooter, the friction can cause the bearing to get worn out. We prevent this from happening by lubricating them regularly.

Start by cleaning/wiping the bearings using with a clean and wet towel, you can spin the wheel at the same-

time which might make it easier for you to clean. After your bearings are clean, it's really important for you to add lubricant to the bearings, if you don't they will get worn very rapidly.

Spray the lubricant generously. Spray directly at the bearings and in the general bearing direction, since they are sealed for better protection. Spin your wheel at the same time to make sure the lubricant is dispersed effectively.

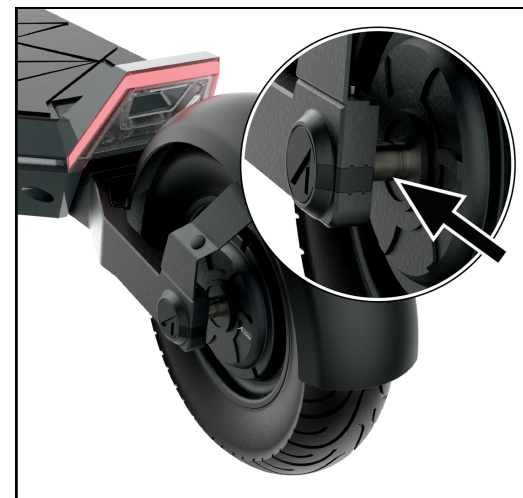

## Suspension lubrication

Similar to the bearings, the suspension must also be lubricated. The constant movement of the suspension causes friction and may result in noises or squeaking sounds.

Ensure the suspension is clean before lubricating. Spray the lubricant inside the spring and on the travel shaft of the spring located inside the coil. Then spray on the top and bottom pivot points of the suspension.

A good way to distribute the lubricant inside of the suspension spring is to jump lightly on the scooter following the application of lubricant. The up-down movement will create friction and will help distribute the lubricant throughout the suspension system.

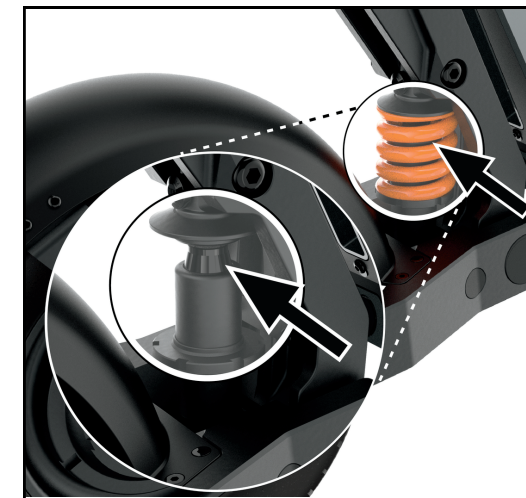

## Drum Brake Adjustment

Note: this section describes a basic adjustment to your brakes. For an in-depth brake adjustment tutorial, please visit the Servicing & Support Center.

**1** Your brakes are an important component of your scooter. If you feel your brakes are not performing as well as they should, you might want to tighten your brakes.

The first point of control of your brakes is your brake handle. Locate the adjustment screw at the connection of the brake line to the brake handle. Turn it counterclockwise to tighten your brake. Turning it clockwise will loosen your brake. If you have reached the maximum position of the adjustment screw and the brakes are not comfortably tight, proceed to the next step.

**2** Find the brake lever located on the right hand side of the wheel and lift it up. Then gently pull the line down to release the tension on the brake line. If the brake is too loose then you can tighten the nob.

**3** Release the line and the lever to check the brake on the handlebars. If you find your brakes are too tight now, then you can reverse the process and loosen the brakes a little bit. A properly adjusted brake should leave about 2 cm of space between the brake lever and the grip handle.

\*For a detailed step-by-step video, please visit our Servicing & Support Center.

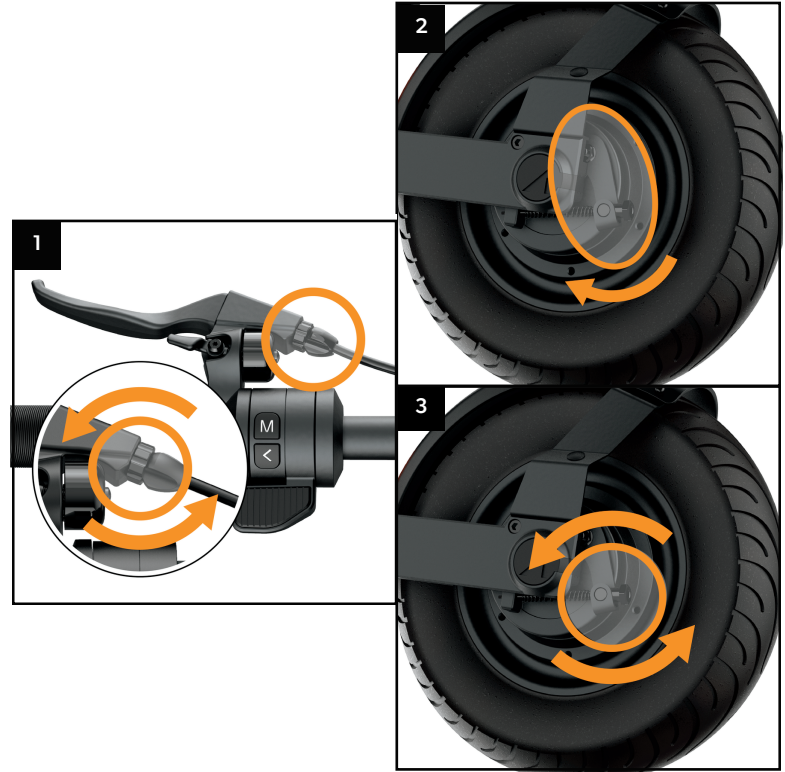

## Folding Mechanism Adjustment

- 1** Use a 3mm allen wrench to loosen the 2 grub screws on either side by turning counter clockwise.
- 2** Loosen both grub screws until they stick out from either side of the folding mechanism.
- 3**
- 4** Pull it down on the folding mechanism until you can see the adjustment screw.
- 5** Using a 6mm allen wrench, tighten or loosen the screw to the appropriate setting.
- 6** Using the 3mm allen wrench, retighten the 2 grub screws.

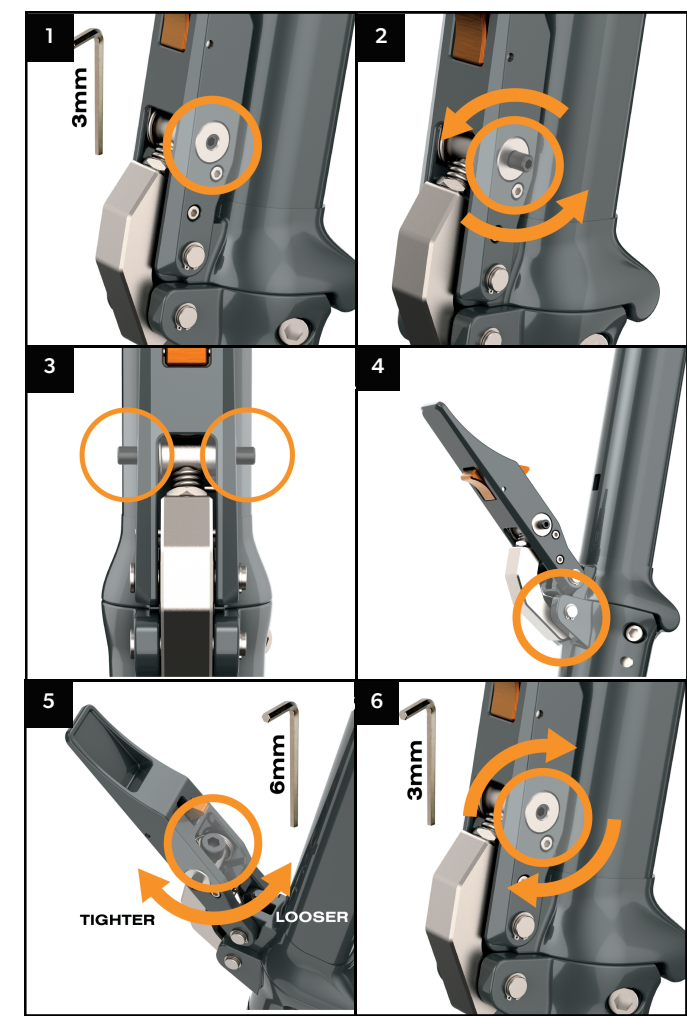

# Screw Tightening

Use the included allen key to tighten the screws highlighted on the following graphics. You can refer to the screw list on the following page for additional information.

Your scooter motor creates vibrations when you ride it, which may cause the screws on your scooter to loosen over time. We recommend checking your screws every few months to make sure they remain tight. You can use a medium strength headlocker adhesive to further improve their stability.

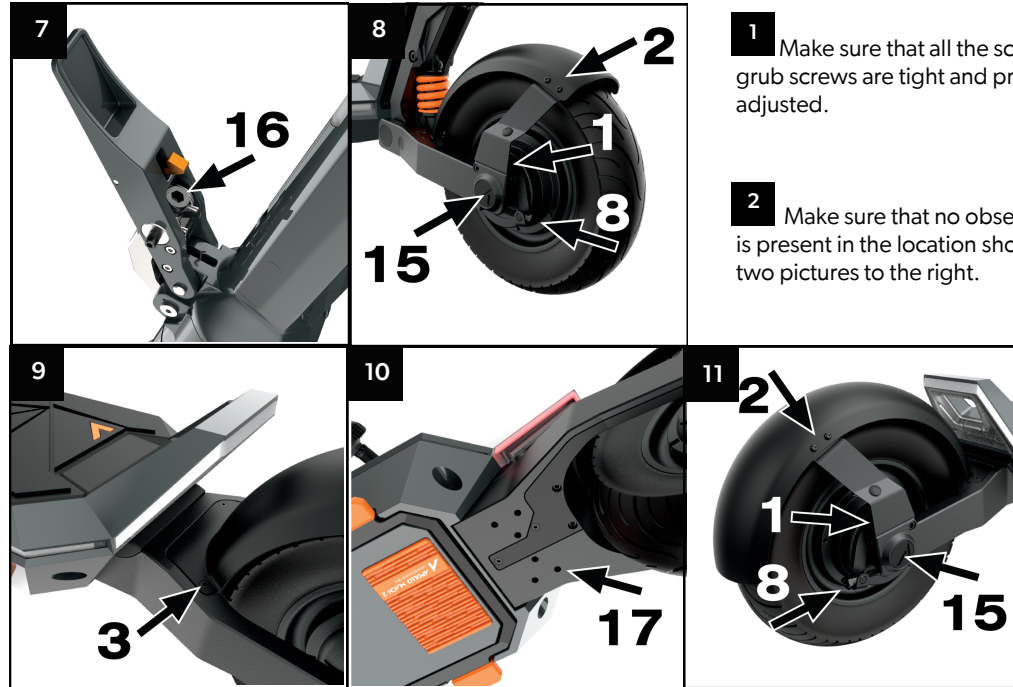
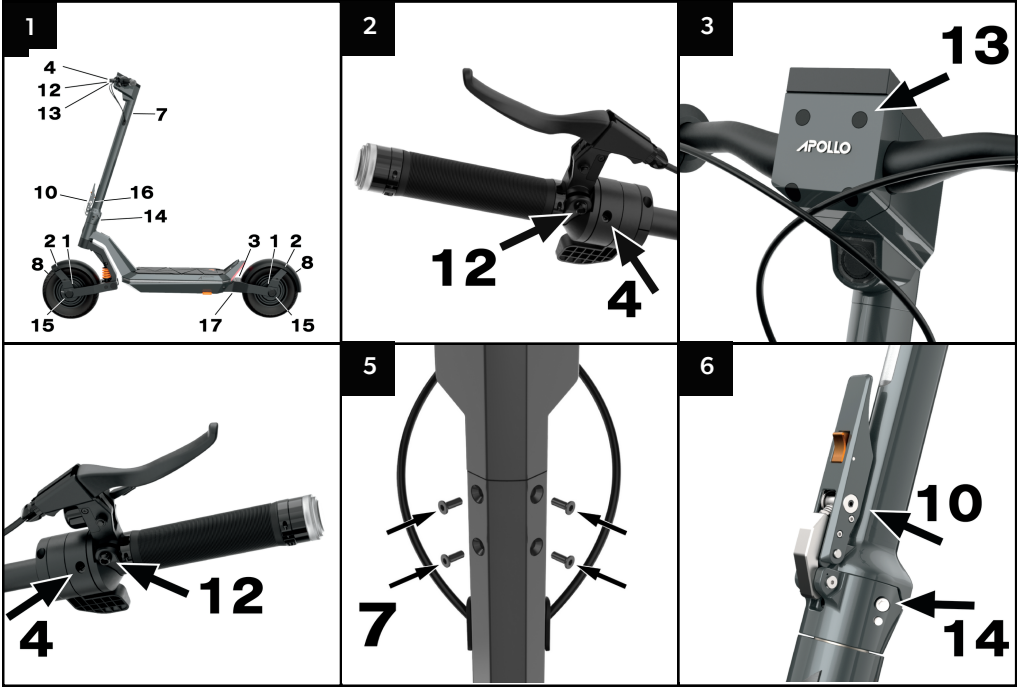

To ensure the longevity of your locking mechanism it is critical to periodically check for any wear and tare that might be happening.

- 1** Make sure that all the screws and grub screws are tight and properly adjusted.
- 2** Make sure that no observable wear is present in the location showed on the two pictures to the right.



## Tool & Screw List

# APOLLO PRO



### TOOL LIST

Allen keys	1x	
Manual	1x	
Valve extender	1x	
Wrench for motor nut	1x	
Air Pump	1x	

### SCREW LIST

	Size	Grade	Torque	
Fender bracket screws/Throttle end cap screw	M4 x 10 x 0.7	8.8	2Nm	
Fender side screw/Neck cover screw/Front motor wire holder	M4 x 8 x 0.7	8.8	1Nm	
Fender bottom screw/Front and Rear swingarm cover	M4 x 10 x 0.7	8.8	1Nm	
Throttle screw	M4 x 16 x 0.7	8.8	2Nm	
Signal light cap				
Handlebar screw	M4 x 10 x 0.7	8.8	2Nm	
Handlebar to stem screw/Kickstand screw	M5 x 16 x 0.8	8.8	5Nm	
Brake screw	M5 x 20 x 0.8	8.8	2Nm	
Quad Lock screw	M5 x 25 x 0.8	8.8	1Nm	
Locking mechanism grub screw	M6 x 10 x 1	12.9	3Nm	
Main body screw	M6 x 25 x 1	12.9	10Nm	
Brake handle screw	M6 x 18 x 1	12.9	2Nm	
Handlebar block screw	M6 x 24 x 1	10.9	5Nm	
Stem to front wheel assembly locking screw	M8 x 30 x 1.25	12.9	10Nm	
Wheel nut	M14 x 1.5		25Nm	

## Handlebar Screw List & Location

Screw number	Screw use/location	Size	Qty.
1	Fender bracket screws/Throttle end cap screw	M4 x 10 x 0.7	1
2	Fender side screw/Neck cover screw/Front motor wire holder	M4 x 8 x 0.7	1
3	Fender bottom screw/Front and Rear swingarm cover	M4 x 10 x 0.7	1
4	Throttle screw	M4 x 16 x 0.7	1
5	Signal light cap		1
6	Handlebar screw	M4 x 10 x 0.7	1
7	Handlebar to stem screw/kickstand screw	M5 x 16 x 0.8	1
8	Brake screw	M5 x 20 x 0.8	1
9	Quad Lock screw	M5 x 25 x 0.8	1
10	Locking mechanism grub screw	M6 x 10 x 1	1
11	Main body screw	M6 x 25 x 1	1
12	Brake handle screw	M6 x 18 x 1	1
13	Handlebar block screw	M6 x 24 x 1	1
14	Stem to front wheel assembly locking screw	M8 x 30 x 1.25	1
15	Wheel nut	M14 x 1.5	1



## Screw List & Location

Screw number	Screw use/location	Size	Qty.
1	Fender bracket screws/Throttle end cap screw	M4 x 10 x 0.7	1
2	Fender side screw/Neck cover screw/Front motor wire holder	M4 x 8 x 0.7	1
3	Fender bottom screw/Front and Rear swingarm cover	M4 x 10 x 0.7	1
4	Throttle screw	M4 x 16 x 0.7	1
5	Signal light cap		
6	Handlebar screw	M4 x 10 x 0.7	1
7	Handlebar to stem screw/Kickstand screw	M5 x 16 x 0.8	1
8	Brake screw	M5 x 20 x 0.8	1
9	Quad Lock screw	M5 x 25 x 0.8	1
10	Locking mechanism grub screw	M6 x 10 x 1	1
11	Main body screw	M6 x 25 x 1	1
12	Brake handle screw	M6 x 18 x 1	1
13	Handlebar block screws	M6 x 24 x 1	1
14	Stem to front wheel assembly locking screw	M8 x 30 x 1.25	1
15	Wheel nut	M14 x 1.5	1

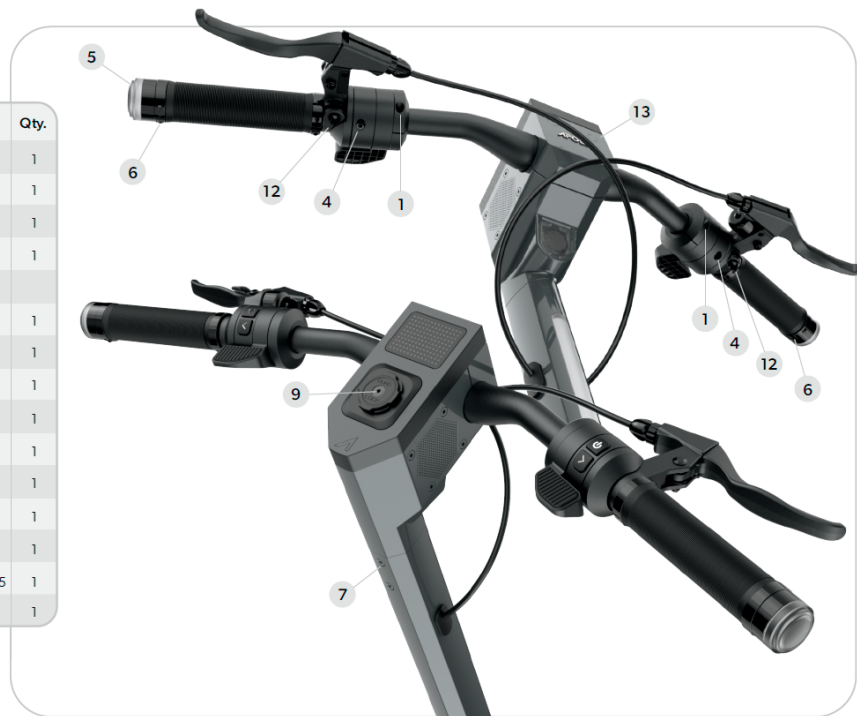

## Maintenance Table

	5km/Every ride	50km	500km	1000km
<b>Tires</b>	Check tire pressure	X	X	Change tire
<b>Brakes</b>	Ensure that the brakes are functional	Ensure that brakes are properly adjusted	Lubricate brake cables Change brake pads	X
<b>Lights</b>	Ensure that all lights work properly	X	X	X
<b>Suspension</b>	X	Ensure that the front and rear suspension is properly tightened	Grease the suspension pin	Perform a full inspection of the suspension. Change the suspension at the slightest sign of wear
<b>Locking mechanism</b>	Ensure that the locking mechanism is tight. Check for sign of wear (See previous page)	Re-tension the locking mechanism	X	X
<b>Battery</b>	X	X	Review Battery health Refer to the app	X
<b>Handlebar components</b>	Ensure that all the handlebar components are properly tighten	X	X	X
<b>Direction/bearings</b>	Ensure no looseness in the steering system	Ensure that the main direction nut and top nut are not getting loose (First 50km)	Ensure that the main direction nut and top nut are not getting loose	X
<b>Under deck screws</b>	X	X	Ensure that the under-deck screws are properly tightened	X
<b>Wheel nut</b>	X	Ensure that the wheel nut are properly tightened	X	X
<b>Motor bolt</b>	X	X	Ensure that the motor bolts are properly tightened	X
<b>Headset screws</b>	X	Ensure that the headset is properly fastened	X	X
<b>Lower stem locking screws</b>	X	X	Ensure that the lower stem locking screws are properly torqued	X
<b>Fender screws</b>	X	X	Ensure that the fender screws are not coming loose	X



Failure to follow the maintenance table may result in serious injuries or death.

### NOTE:

For comprehensive details on maintenance tasks and step-by-step guides, please visit our Apollo Pro maintenance guide located on the Servicing & Support Center:



# TROUBLESHOOTING

## Failure displays / Error Codes

If a malfunction occurs while using your Apollo Pro, then one of the following failure display codes will appear on the screen:

### PLEASE NOTE:

For full troubleshooting video library, visit our Servicing & Support Center



E1 F1

### BRAKE ERROR

F1 is reported when the power-on self-test fails. E1 is reported when the error occurs during operation.

#### Error Code:

If E1/F1 is reported, the brake handle or it's connection could be faulty.

#### Solution 1:

Check whether the brake handle wire is connected properly.

#### Solution 2:

Replace brake handle to test, if the error code goes away the handle was the issue.

#### Solution 3:

Replace the handlebar assembly to test, if the error code goes away the display was the issue.

E2 F2

### THE THROTTLE ERROR

F2 is reported when the power-on self-test fails. E2 is reported when the error occurs during operation.

#### Error Code:

If E2/F2 is reported, the throttle or it's connection could be faulty.

#### Solution 1:

Check whether the throttle wire is connected properly and the throttle isn't out of position.

#### Solution 2:

Replace the throttle to test, if the error code goes away the throttle was the issue.

#### Solution 3:

Replace the handlebar assembly to test, if the error code goes away the display was the issue.

E3

### COMMUNICATION ERROR

E3 will show the error in power system running.

#### Solution 1:

Check if the connection between the handlebar assembly and the communication cable in the stem is good.

#### Solution 2:

Replace handlebars to test, If the error code goes away the handlebars were the issue.

#### Solution 3:

Replace the controller to test, if the error code goes away the controller was the issue.

E4

### OVER CURRENT PROTECTION

If E4 error is reported continuously, it is considered to be hardware fault of controller.

#### Solution 1:

Check whether the brake handle wire is connected properly.

#### Solution 2:

Replace brake handle to test, if the error code goes away the handle was the issue.

#### Solution 3:

Replace the handlebar assembly to test, if the error code goes away the display was the issue.

E7

### MOTOR SENSOR ERROR

If E7 is reported this means that a faulty motor sensor is present.

#### Solution:

Replace the motor to test, if the error goes away the motor was the issue.

E5

### UNDER VOLTAGE PROTECTION

If E5 is reported continuously, check whether the battery voltage is too low (Below 30 Volts).

#### Solution:

Replace with a new battery to test, if the error goes away the battery was the issue.

E8

### MOTOR PHASE LOSS

If E8 is reported this means that one or more phase connectors are not properly connected or properly working.

#### Solution 1:

Check if the phase wires are properly connected.

#### Solution 2:

Replace the controller to test, if the error goes away the controller was the issue.

#### Solution 3:

Replace the motor to test, if the error goes away the motor was the issue.

E6

### OVER VOLTAGE PROTECTION

If E6 is reported the battery voltage is too high.

#### Solution:

The battery voltage is too high, avoid sudden braking, rushing actions and it will return to normal when part of the power has been used up.

E9

### CONTROLLER ERROR

If E9 is reported continuously, this means that the controller is faulty.

#### Solution:

Replace the controller to test, if the error goes away the controller was the issue.



# WARRANTY & SERVICES

## Warranty Structure

All Apollo Scooters are covered with a 12-Month Limited Warranty. For more details about the warranty scan the QR code below.



## Apollo Plus

Apollo Plus is a suite of services that will support our customers along every facet of scooter ownership. Apollo Plus provides peace of mind services to protect your orders while shipping, guarantee they are operating at the highest standard, and ensures you are back to riding as quickly as possible in case something goes wrong.

## UL COMPLIANCE STATEMENT

Operating Temperature Range: -10°C ~ 40°C  
Charge Temperature Range: 0°C ~ 25°C  
Minimum and Maximum Rider Weight: 50~150 kg  
Maximum speed: 20 km/h

**We hope you enjoy your Apollo Pro Scooter as much as we loved developing it!**

If you want to stay connected with us and learn all about our future innovations, you can follow us on:



@APOLLO SCOOTERS



@RIDEAPOLLO



APOLLO SCOOTERS



@RIDEAPOLLO

# FCC COMPLIANCE STATEMENT

## FCC COMPLIANCE STATEMENT

This device complies with part 15 of the FCC Rules.

Operation is subject to the following two conditions:

- (1) This device may not cause harmful interference, and
- (2) this device must accept any interference received, including interference that may cause undesired operation.

Note:

This equipment has been tested and found to comply with the limits for a Class B digital device, pursuant to Part 15 of the FCC Rules. These limits are designed to provide reasonable protection against harmful interference in a residential installation. This equipment generates, uses and can radiate radio frequency energy and, if not installed and used in accordance with the instructions, may cause harmful interference to radio communications.

However, there is no guarantee that interference will not occur in a particular installation. If this equipment does cause harmful interference to radio or television reception, which can be determined by turning the equipment off and on, the user is encouraged to try to correct the interference by one or more of the following measures:

- Reorient or relocate the receiving antenna.
- Increase the separation between the equipment and receiver.
- Connect the equipment into an outlet on a circuit different from that to which the receiver is connected.
- Consult the dealer or an experienced radio/TV technician for help.

Warning: Changes or modifications to this unit not expressly approved by the part responsible for compliance could void the user's authority to operate the equipment.

## FCC RADIATION EXPOSURE STATEMENT

The device has been evaluated to meet general RF exposure requirement.  
The device can be used in mobile(min20cm) exposure condition.

## IC STATEMENT

This device complies with Canada Industry licence-exempt RSS standard(s). Operation is subject to the following two conditions:

- (1) this device may not cause interference; and
- (2) this device must accept any interference. Including interference that may cause undesired operation of the device.

## Avis d'Industrie Canada

Le présent appareil est conforme aux CNR d'industrie Canada applicables aux appareils radio exem pts de licence L'exploitation est autorisée aux deux conditions suivantes:

- 1) l'appareil ne doit pas produire de brouillage; et
- 2) l'utilisateur de l'appareil doit accepter brouillage radioélectrique subi même si le brouillage est susceptible d'encompromettre le fonctionnement. mauvais fonctionnement de l'appareil.  
CAN ICES-3 (B)/ CAN NMB-3 (B)

## RADIATION EXPOSURE STATEMENT

This equipment complies with IC radiation exposure limits set forth for an uncontrolled environment. This equipment should be installed and operated with minimum distance 20cm between the radiator & your body.

## Déclaration d'exposition aux radiations:

Cet équipement est conforme aux limites d'exposition aux rayonnements IC établies pour un environnement non contrôlé. Cet équipement doit être installé et utilisé avec un minimum de 20 cm de distance entre la source de rayonnement et votre corps.

**APOLLO**

USA

**apolloscooters.co**

CANADA

**apolloscooters.ca**