

PHANTOM

INTRODUCTION

Hello World

Thank you for purchasing the Apollo City. The electric scooter industry is still young and it takes forward-thinking customers like yourself to advance it. We hope you enjoy your new scooter as much as we loved developing it.

Please be aware that the model depicted in this manual serves as a general representation. Your specific model may feature slight differences in design or functionality. For the most accurate and current user manual, please visit our Servicing & Support Centre to access the latest version.

How to get help?

We're here to help regardless of the issue you are facing. Visit our Support Page below to access our Servicing & Support Center, as well as to find various ways to get in touch with our team.



⚠ WARNING

Incorrect assembly, maintenance, or use of your Apollo scooter can cause component or performance failure, loss of control, serious injury, or death. Even if you're an experienced scooter rider, you must read and understand the entire manual and any documentation provided for subcomponents or accessories before riding. In the event of a malfunction or damage to any of the components during set up or use, please discontinue set up or use and contact our support team through our Support Page. If you are not sure you have the experience, skills, and tools to correctly perform all assembly steps in the manual and the assembly video, consult our support team or a local electric scooter shop.

For your safety and that of others, please read and make sure you understand all of the warnings and instructions contained in this Manual. **FAILURE TO FOLLOW THESE WARNINGS AND INSTRUCTIONS CAN RESULT IN SERIOUS INJURY OR DEATH.**

Contents

Specs	4
Unboxing	5
Testing	8
Operation	10
Display	15
Battery Info &	16
Low Battery	16
General Safety	17
Safe riding instructions & Warnings.....	18
Maintenance	20
Screw Chart	24
Troubleshooting	28
Warranty & Services	30



SPECS

Net Weight	66 lb (29 kg)
Dimension	Height x Width : 51" x 28" (130cm x 71 cm)
Maximum Load	300 lb (136 kg)
Maximum Grade %	25 degrees
Maximum Speed	66 km/h (41 mph)
Range	~64 km (~40 miles)
Battery	126 x 18650 (23 400mah) Lithium
Batteray Type	52V 23.4aH
Power Requirement	Input: AC 110-220V Output: 58.8V 2A
Charging Time	Approx. 12 hours
Wheels	66 lb (29 kg) Height x Width : 51" x 28" (130cm x 71 cm) 300 lb (136 kg) 25 degrees 66 km/h (41 mph) ~64 km (~40 miles) 126 x 18650 (23 400mah) Lithium 52V 23.4aH Input: AC 110-220V Output: 58.8V 2A Approx. 12 hours
Motor	Dual motor - 2 motor of 1200W
Brakes	Rear disc, front disc, and electric regenerative brake. Uses a hydraulic tube filled with hydraulic fluid that closes the caliper with pressur (stronger braking usually)
IP Water Resulance Rating	IP54
Suspension	4 Spring System

UNBOXING

WARNING

Improper assembly of your Apollo scooter can cause component or performance failure resulting in loss of control, serious injury, or death. In the event of a malfunction or any damage to any of the components during set up of your scooter, please discontinue set up immediately, do not ride the scooter, and contact our support team. If you are not sure you have the experience, skills, and tools to correctly perform all assembly steps in the manual and the assembly video, consult our support team or a local electric scooter shop.

Intro

Setting up your scooter right is the single most important step to your safety.

Please note that this process is also available in video format through our Servicing & Support Center.

We recommend having the following items ready prior to starting the setup process:

- Box cutters or knife
- Stool or bench
- Air pump
- Someone to help

Unbox your scooter

Open the box using the box cutter and fold open the top. Inside you should see protective styrofoam along with the following contents:

- Apollo City electric scooter
- Manual
- Charger and cable
- Hex key
- Screw Kit

If any of these items are missing, please contact us immediately.

With the help of someone, remove the scooter from the box and place it on a flat surface.

We recommend using a stool or bench as the wheels need to be able to spin freely.

Carefully remove the protective material from the scooter and set it aside. We require you to keep both the styrofoam and the box in case you need to ship your scooter back to us. Otherwise recycle the materials wherever possible.

Prepare for Assembly

⚠ WARNING

Always follow the below instructions when unfolding your scooter and prior to each ride. Failure to ensure the safety button of the folding mechanism is clipped into the scooter stem and to ensure the stem is fully secured before your ride may lead to the stem coming undone during your ride, which can result in loss of control, serious injuries and death. Do not operate the scooter if you notice anything wrong with the scooter stem, the safety button, or the locking mechanism.

Unfolding

1 The first step is to unfold your Apollo Phantom . To do so, ensure the hook is not clipped into the rear foot rest. If it is, push down on the system and unhook it from the rear foot rest.

2 Locate the safety pin inserted into the folding mechanism and gently remove it. This will allow the stem of the scooter to be lifted in the following step.

3 Unfold the stem by pulling it to a vertical position. Ensure you do so until the stem is completely vertical.

4 Fold the latch all the way up.

5 Place the safety pin back in the designated location, ensuring it is pushed all the way in. This acts as an additional safety mechanism, keeping the stem locked in place.

6 Next, make sure you turn the ring to secure the latch in place. This will prevent that latch from unfolding.

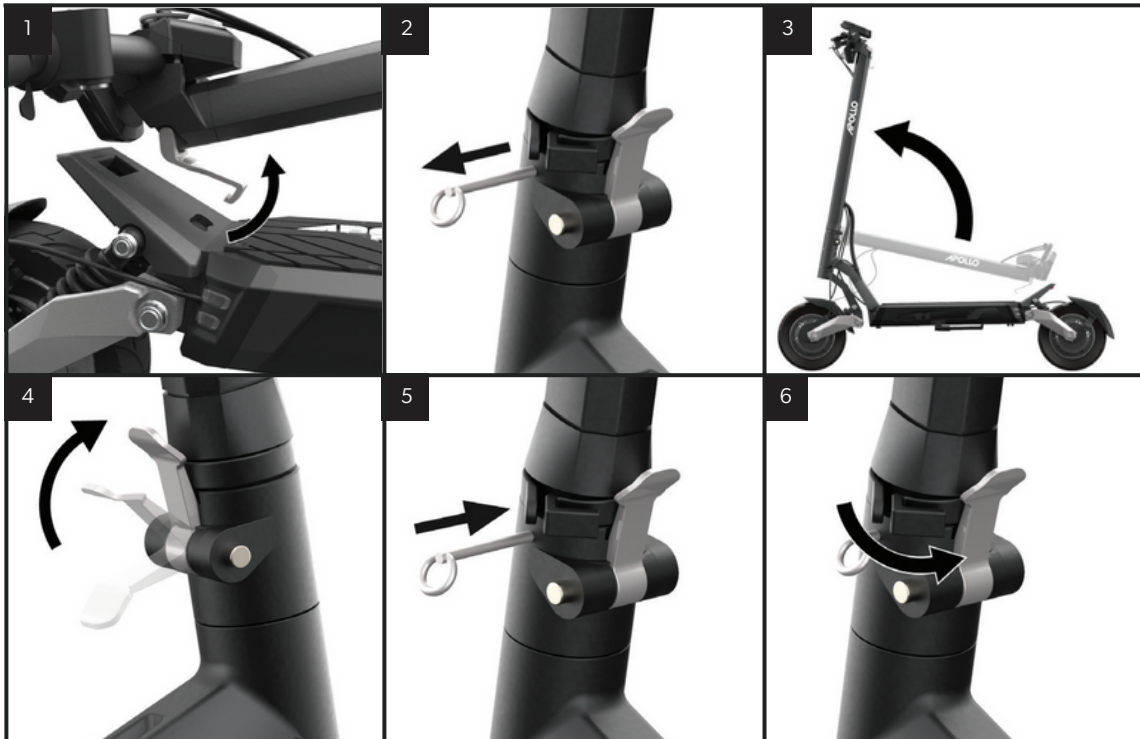

Attach handlebar

- 1 On the stem bar, there is a light at the top with two screws. Remove the two screws with the hex key.
- 2 Once removed, you will see the light fixture come off the clamp revealing a total of four screws that hold the handlebar clamp in place. Remove these four screws until the front half of the clamp comes off.
- 3 Next, grab the handlebars and place them inside the clamp. Hold the handlebars with one hand and place the clamp back in position with the other.
- 4 The next step is to put the screws back in place using the hex key, start with bottom left screw followed by the top right screw. This will create enough pressure and hold the handlebar still while still allowing you to adjust it.
- 5 Rotate the handlebar until you find the most comfortable position.
- 6 Next screw in place the remaining two screws and tighten the clamp until all screws reach their maximum position.

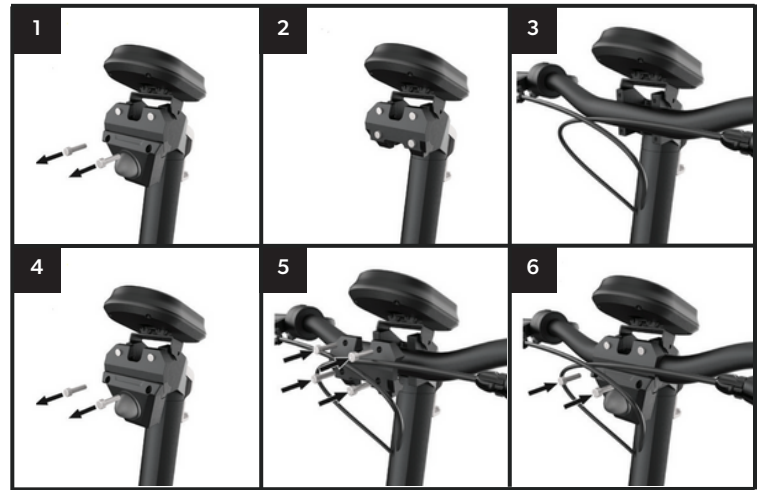

Command Center

- 1 You will notice that the display and brakes all come loose. The following steps will guide you on how to adjust them and secure these elements in place.
- 2 Start by adjusting the left hand side brakes. Start by rotating them until they are in a comfortable position.
- 3 Next, secure the left brakes in place. Find the screw in the rear and tighten using the hex key included.
- 4 Repeat steps 1 and 2 for the right hand side brake.
- 5 Finally, its also important to adjust and secure the display. Move it until it is in a comfortable position.
- 6 Tigthen the screws located on the rear of the display.

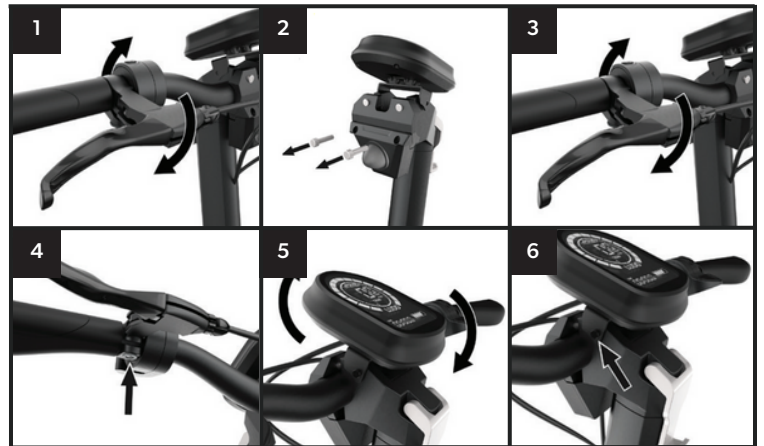

TESTING

To perform the test, place your scooter above ground, in a position where the wheels are not touching any surface. This will allow you to test the acceleration and brakes without getting on your scooter.

1

Act ion	Result
Long press on the power button	Turn ON scooter
Long press on the power button (Scooter must be completely still)	Turn OFF scooter
Left signal light button	Turns ON left signal light
Right signal light button	Turns ON right signal light
1x Mode button	Cycles through time, trip, ODO, Voltage, Remaining Km
1x quick power button	Gear change
2x quick power button	Headlight ON/OFF
3x quick power button	Switch between Ludo/ non Ludo
4x quick power button	Cruise control ON/OFF
5x quick power button	Park mode ON/OFF



2

Push on the thumb throttle on the right hand side of your handlebar. This should make the wheel begin to spin. If your wheel doesn't begin spinning, contact us immediately.



3

Now test your brakes - Hold the throttle on the right side of your handlebar for 5 seconds, then release and slam both brakes at the same time. The wheel should stop immediately.



4 Next, grab an air pump and locate the air valve on the front tire. Remove the safety cap and attach the pump tube to the tire valve. Turn on the air pump and read the PSI measure - the ideal tire pressure for the Phantom is 50PSI.



5 Inflate or deflate the tire as needed until the pressure is 50PSI. Repeat the step with the rear tire.

Congratulations, you have successfully set up your new Apollo Phantom .

If you experience difficulties with the setup at any step, please refer to our help centre at [apolloscooters.co/support](https://www.apolloscooters.co/support) for a video walkthrough of the process. Alternatively, you can contact our support team at support@apolloscooters.co for assistance.



OPERATION

WARNING

Improper assembly of your Apollo scooter can cause component or performance failure resulting in loss of control, serious injury, or death. In the event of a malfunction or any damage to any of the components during set up of your scooter, please discontinue set up immediately, do not ride the scooter, and contact our support team. If you are not sure you have the experience, skills, and tools to correctly perform all assembly steps in the manual and the assembly video on the Servicing & Support Center, consult our support team or a local electric scooter shop.

Charging

This section focuses on how to charge your scooter correctly. For information about battery health and best practices, please review the Battery Information section.

The battery pack comes with a built-in battery management system. This includes overcharging protection amongst other features, allowing your scooter to stay plugged in even after it is fully charged.

Please note that this applies to short periods of overcharging, such as the scooter being plugged in overnight. Please do not leave the scooter plugged in and charging for extended periods of time as it may result in battery damage or fire.

1 Ensure both parts are connected well

2 Locate charging port

3 Insert softly

4 Connect to outlet

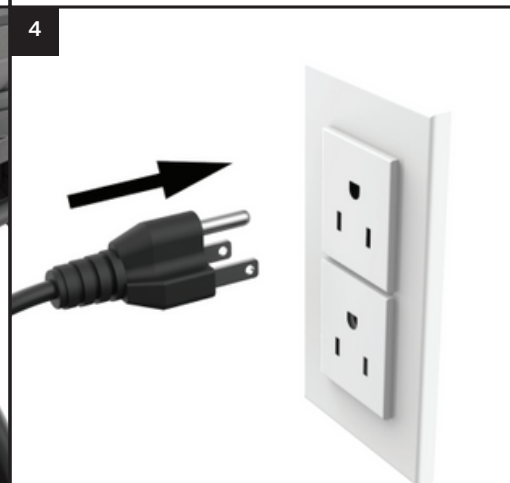
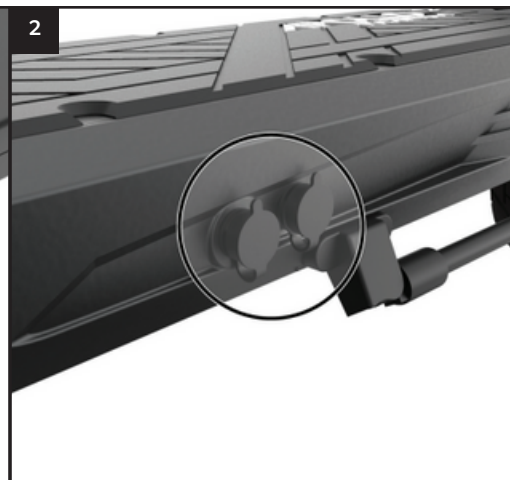
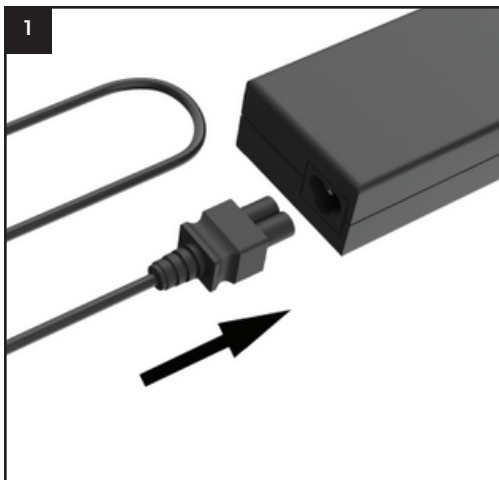

How to brake

The Apollo Phantom is equipped with regenerative braking. To brake, press on the brake levers located on either side of your handlebar. The harder you press, the harder you will brake.

Regenerative braking not only helps you stop but charges the battery up to 10% as you use the brakes. Recharge as you ride.

Throttle

To accelerate, press on the throttle. The throttle is responsive to the amount of pressure applied, you will achieve a faster acceleration the more pressure you apply.

KickStart

KickStart is always ON out of the box. To turn OFF KickStart, access the settings within the App

Changing Gears

To shift gears press the power button quickly twice. The gears will cycle through 1, 2, and 3.

1st gear - The first gear with a max speed of 3 mph (6 km/h)

2nd gear - The max speed for this gear is 9 mph (15 km/h)

3rd gear - Top speed 12 mph (20km/h)

Ludo mode, 3x quick power button

The top speed for each gears can be changed in the app.

Lights

To turn on the lights, 1x quick power button, Headlight on/off.

Press the arrow buttons for signals.

App

You can manage your settings through the Apollo App. The settings you can manage through your App are:

- Control Gear
- Control Speed Metrics (KMH/MPH)
- Control top speed limit
- Control acceleration and regen brake
- Control ON/Off cruise control
- Control the time it takes for the cruise control to turn on
- Control KickStart On/Off mode

The Apollo App is available for iOS and Android. To download it, visit our website apolloscooters.co or look for it in your APP store as Apollo Scooters.

You can also download it using the following QR code:

App updates may be rolled out at any moment to improve the user experience. For any App related issues or for the latest App related information, please reach out to our support team through apolloscooters.co/support who will provide the latest information.

Turning it ON/OFF

To turn on/off, long press on the power button.



In rain or wet weather, braking distances increase. A failure to take this into consideration in such conditions can cause component or performance failure, loss of control, serious injury, or death.



Folding

- 1** To fold, begin by locating the safety ring and turn it clock-wise to unlock the folding lever.
- 2** Identify the safety pin and pull it out to release the safety mechanism.
- 3** Next, hold the stem in place with one hand and with your other hand pull down the folding latch.
- 4** Fold the stem all the way down.
- 5** Place the safety pin back in the designated location. Make sure to push it all the way in.
- 6** Attach the hook on the stem to the locking ring located at the end of the deck, near the foot rest and the rear wheel. Attach the hook to the locking ring.

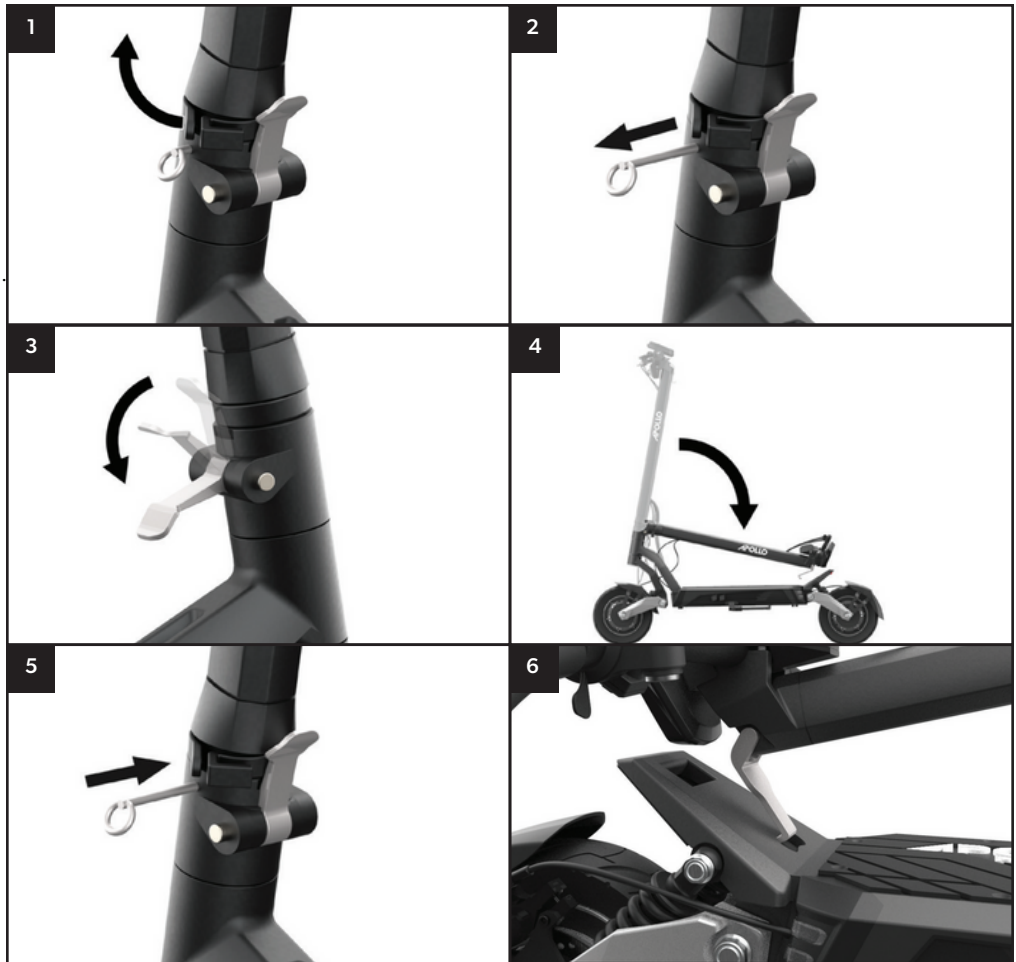

Handlebar features

- 1 Display
- 2 Power button
- 3 Mode button
- 4 Right turn signal
- 5 button Left turn signal
- 6 button Acceleration
- 7 throttle regen Throttle
- 8 Brakes



DISPLAY

⚠ WARNING

Improper assembly of your Apollo scooter can cause component or performance failure resulting in loss of control, serious injury, or death. In the event of a malfunction or any damage to any of the components during set up of your scooter, please discontinue set up immediately, do not ride the scooter, and contact our support team. If you are not sure you have the experience, skills, and tools to correctly perform all assembly steps in the manual and the assembly video at on our Servicing & Support Center, consult our support team or a local electric scooter shop.

NOTICE

When there is only one battery bar remaining, it is advisable to stop using the scooter if possible and to recharge it in order to prolong the lifespan of the battery, a deep discharge will decrease the lifespan of the battery.

NOTICE

While riding you may notice an occasional beeping noise. It has been programmed to indicate when you go are riding above the speed of the gear selected.

The display screen, located on handlebars, shows you the speed, speed units, the battery charge, selected gear, and any failure displays.

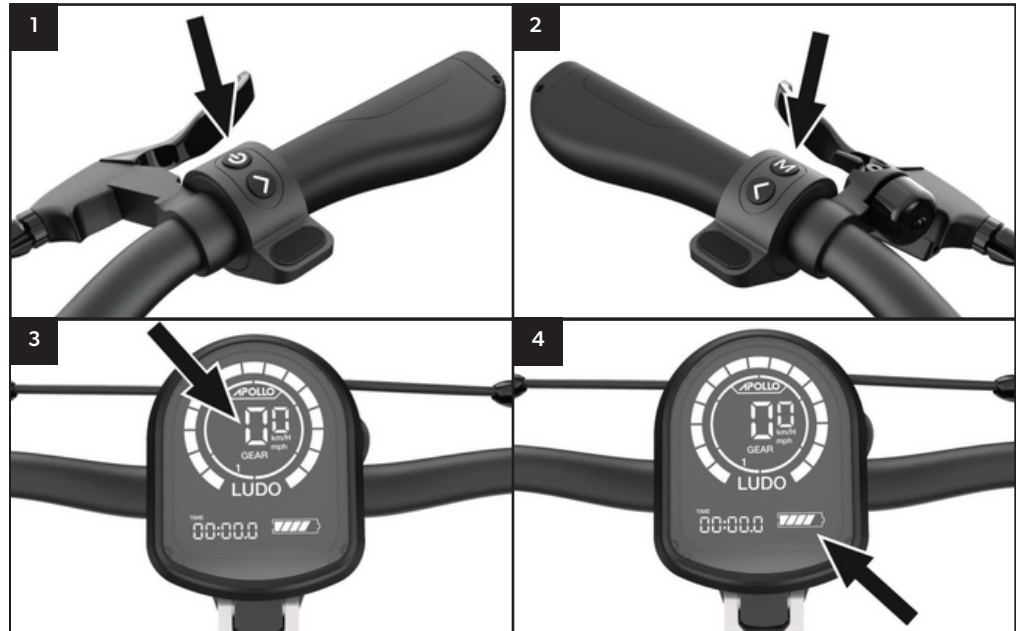

BATTERY INFO & LOW BATTERY

NOTICE

When there is only one battery bar remaining, it is advisable to stop using the scooter if possible and to recharge it in order to prolong the lifespan of the battery, a deep discharge will decrease the lifespan of the battery.

Charging

- Charge the scooter fully after every ride. This will prolong the battery life.
- When charging, wait for the charger light to turn green. The charging process will then be complete and all the cells will have been balanced by the battery management system.
- If not used, power on the scooter once at least once a month to check the charge level. Ideally, the charge level should be between 70% and 90%.

Storage

- The storage temperature needs to be between 10°C–25°C / 50°F–77°F
- For long term storage (such as the winter season), the ideal battery level is approximately 70%. This is based on the fact that at 70% charge level, the energy inside the battery cells is the most stable.

Caution

- Do not leave the scooter in cold spaces (such as unheated garages or outdoor sheds).
- Do not leave the battery undercharged for 48 hours or more. This can result in battery damage which is not covered by warranty.
- Wait 30 minutes after a ride before attempting to charge the battery.
- Do not use chargers that are not sold or approved by Apollo Scooters.
- Keep the battery away from heat or fire, a failure to do so may result in a serious injury or death.
- If there is any damage to the battery, the scooter will not turn after charge or it will not charge.
DO NOT ATTEMPT TO OPERATE THE SCOOTER.
Contact us immediately via our Support Page.

GENERAL SAFETY

WARNING

Apollo Scooters are designed to be used and operated by adults and should not be used by anyone younger than 18 years of age. Should the rider have any disabilities or impairments (visual, hearing, language, seizure, etc), please consult your physician before any ride or purchase of an electric scooter.

You are responsible to perform due diligence, understand and follow all laws, rules and regulations, for the safe and lawful operation of your electric scooter, in the locations in which you choose to operate it. If not used properly or lawfully, electric scooters can lead to injury or death. By purchasing an Apollo scooter, you assume the responsibility for its safe and lawful operation as well as the risks for any failure to safely and lawfully operate it. Any fines due to illegal or unauthorized use, including but not limited to any failures to wear protective equipment, are your responsibility. Should you have any questions or concerns, feel free to contact us via [our Support Page](#).

Please read the entire manual carefully. If uncertain about any section, contact us directly or visit our Servicing & Support Center to find more information. We always recommend starting slow and getting used to the scooter before riding at faster speeds and for longer distances.

Road safety & legislation

Your Assumption of Risk For Road Safety and Observation of All Laws.

You are responsible to perform due diligence, understand and follow all laws, rules and regulations, for the safe and lawful operation of your electric scooter, in the locations in which you choose to operate it. If not used properly or lawfully, electric scooters can lead to injury or death. By purchasing an Apollo scooter, you assume the responsibility for its safe and lawful operation as well as the risks for any failure to safely and lawfully operate it. Any fines due to illegal or unauthorized use, including but not limited to any failures to wear protective equipment, are your responsibility. Should you have any questions or concerns, feel free to contact us via our Support Page.

Education

Please read the entire manual carefully. If uncertain about any section, contact us directly via our Support Page or visit our Servicing & Support Center to find more information. We always recommend starting slow and getting used to the scooter before riding for longer distances.

SAFE RIDING INSTRUCTIONS & WARNINGS

WARNING

Apollo Scooters are designed to be used and operated by adults and should not be used by anyone younger than 18 years of age. Should the rider have any disabilities or impairments (visual, hearing, language, seizure, etc), please consult your physician before any ride or purchase of an electric scooter.

You are responsible to perform due diligence, understand and follow all laws, rules and regulations, for the safe and lawful operation of your electric scooter, in the locations in which you choose to operate it. If not used properly or lawfully, electric scooters can lead to injury or death. By purchasing an Apollo scooter, you assume the responsibility for its safe and lawful operation as well as the risks for any failure to safely and lawfully operate it. Any fines due to illegal or unauthorized use, including but not limited to any failures to wear protective equipment, are your responsibility. Should you have any questions or concerns, feel free to contact us via our Support Page.

Please read the entire manual carefully. If uncertain about any section, contact us directly or visit our Servicing & Support Center to find more information. We always recommend starting slow and getting used to the scooter before riding at faster speeds and for longer distances.

- ALWAYS wear a helmet when riding.
- ALWAYS inspect your scooter before riding. Do not ride if you notice any damage to your scooter.
- ALWAYS make sure the safety button of the folding mechanism clipped into the stem and that stem is fully secured before beginning your ride.
- ALWAYS keep both hands on the handlebar when riding.
- ALWAYS ride safely and at an appropriate speed to avoid falls and collisions.
- ALWAYS avoid contact with moving parts of the scooter, such as the motor and wheels.

- NEVER ride under the influence of any drugs, alcohol or substance that could limit or affect judgement, control or rider safety. You must always ride with a fully conscious and sober mind to ensure a safe ride.
- NEVER exceed the maximum capacity weight of the scooter.
- NEVER ride on sidewalks, motorways or highways.
- NEVER ride with more than one rider.
- NEVER ride on stairs, jump the scooter, or operate it at high speeds over bumps for risk of loss of control.
- NEVER race or perform stunts with the scooter.

Operating in Wet Conditions

WARNING

In rain, snow, ice, or other wet conditions, braking distances increase and the risk of loss of control increases. Riding in these conditions, and/or failing to take into account increased braking distances, can cause loss of control, serious injury, or death.

Protective Gear

WARNING

We strongly recommend wearing protective equipment any time the scooter is in use. In addition to always wearing a helmet, it is recommended that you also wear other protective gear, including but not limited to, knee and elbow pads, and protective armor.

Avoid Exposure to Water and humidity

NOTICE

You must avoid exposing your scooter to water and humidity. Apollo scooters are not waterproof and are not designed for extreme or prolonged exposure to water or humidity. Operating your scooter in rain, wet, or other extreme (ice, snow, etc.) conditions can cause component or performance failure, in addition to loss of control, serious injury, or death. Please note that any damage to the scooter due to water exposure is not covered by warranty.

MAINTENANCE

WARNING

Failure to properly maintain your Apollo scooter can cause component or performance failure, loss of control, serious injury, or death.

NOTE:

This section is available in a video tutorial which can be found on our Servicing & Support Center

Getting started

We recommend doing maintenance according to the maintenance table to make sure all of the components are working properly. Below you can find the steps to perform a basic maintenance of your Apollo Phantom. However, if you need additional information or help, please contact our support team directly through our Servicing & Support Center.

A tune up consists of the following steps:

- Tire pressure check
- Bearing lubrication
- Suspension lubrication
- Brake adjustment
- Screw tightening

You will need a few things to get these done, all of them can be purchased at a local hardware store. If you have difficulty locating these items, contact our support team for help:

- Electric tire pump/inflator
- Lithium grease in spray format
- Brake pads
- Blue Loctite
- Basic toolkit

These are low cost items that, if used regularly, can make your scooter last dramatically longer. In other words, they're an investment definitely worth making.

Tire pressure

Let's get started with a tire pressure check, which will allow you to see the tire pressure of your tires. The ideal tire pressure for Apollo scooters is 50PSI. It is important to keep you tires at the correct pressure for a better riding experience and to avoid getting a flat tire.

To get started place your scooter on a bench, chair, or box, making sure that the tires are easy to access. Start with the front tire - locate the air valve and remove the safety cap.

Attach the air hose and flip the latch to tighten it. You should be able to power on your electric pump and get a read of the current tire pressure. If it's below 50PSI, start to inflate until the dial reads exactly 50.

If the pressure is higher than 50PSI, deflate the tire by pressing down on the air valve mechanism. To do so, find a small object such as an the hex key provide it and insert it into the air valve. You will hear the air escape. Do so until the tire feels flat, then reattach the electric pump and inflate until at 50PSI.

When the tire is properly inflated, put the cap back on the air valve.

Repeat the process with the other tire.

Bearing lubrication

The next maintenance step is to lubricate the bearings. Your bearings are the connection between the rotating wheels of your scooter and the non-rotating frame that holds them stable. As you use your scooter, the friction can cause the bearing to get worn out - we prevent it from happening by lubricating it regularly.

Start by cleaning the bearings using a clean and wet towel, you can spin the wheel at the same time which might make it easier for you to clean. After your bearings are clean, it's really important for you to add lubricant to

the bearings, if you don't they will get worn very rapidly.

Spray the lubricant generously. Spray directly at the bearings and in the general bearing direction, since they are sealed for better protection. Spin your wheel at the same time to make sure the lubricant is dispersed effectively.

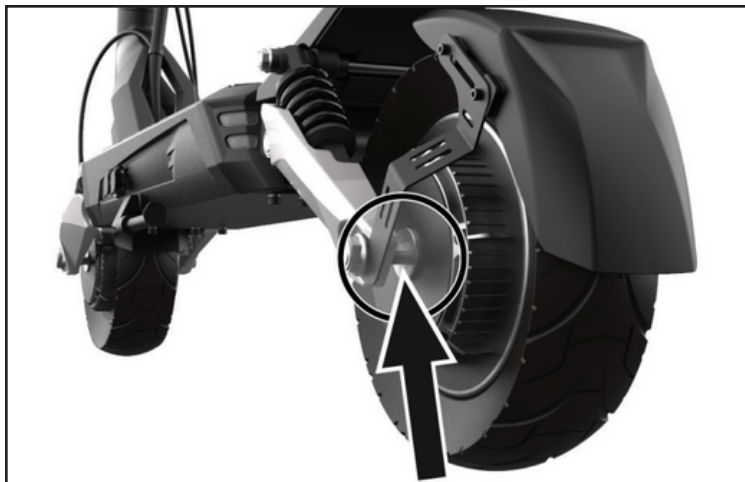

Suspension lubrication

Similar to the bearings, the suspension must also be lubricated. The constant movement of the suspension causes friction and may result in noises or squeaking sounds.

Ensure the suspension is clean before lubricating. Spray the lubricant inside the spring and on the travel shaft of the spring located inside the coil. Then spray on the top and bottom pivot points of the suspension.

A good way to distribute the lubricant inside of the suspension spring is to jump lightly on the scooter follow-

ing the application of lubricant. The up-down movement will create friction and will help distribute the lubricant throughout the suspension system.

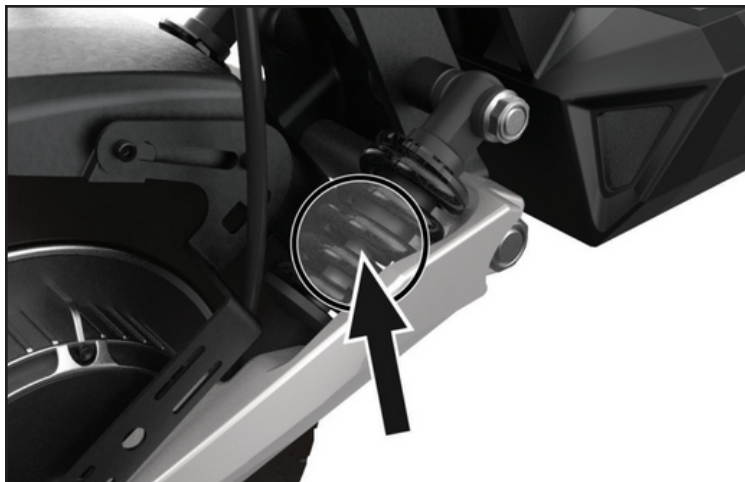

Disc Brake Adjustment

Note: this section describes a basic adjustment to your brakes. For an in-depth brake adjustment tutorial, please visit the Servicing & Support Center.

- 1 Locate brake nob - turn clockwise Locate
- 2 screws that hold brake, loosen
- 3 Loosen the other two screws
- 4 Align disc brake
- 5 Turn the wheel & tighten screws
- 6 Tighten screws
- 7 Locate lever and turn it upwards
- 8 Tighten screw on lever
- 9 Tighten nob

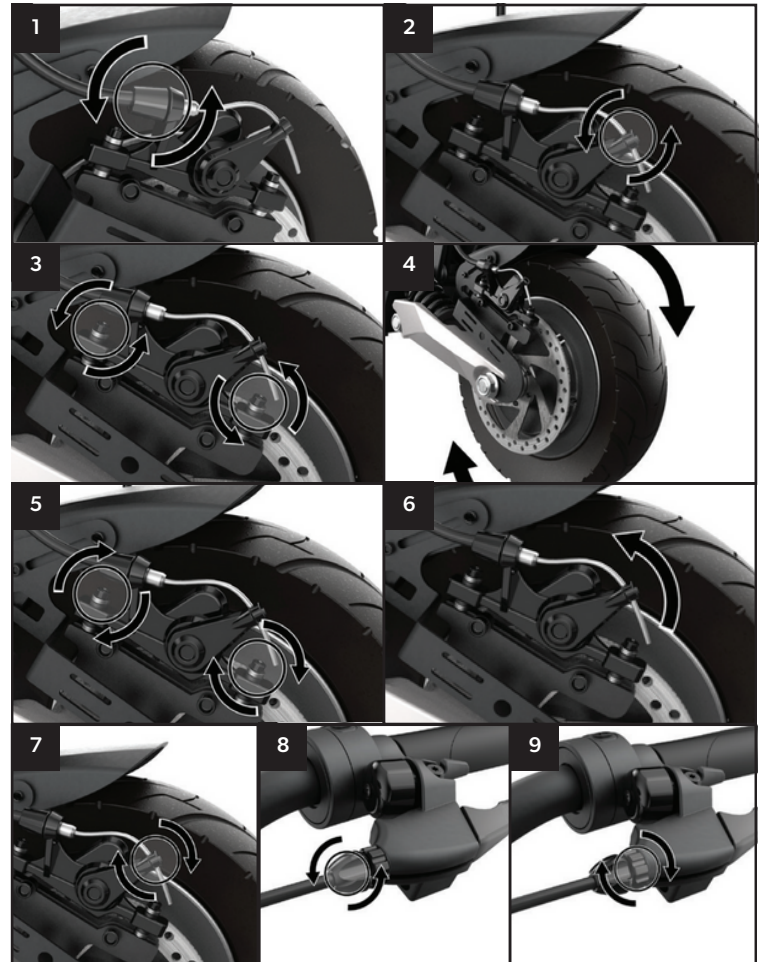

*For a detailed step-by-step video, please visit our help desk center at apolloscooters.co/support

Screw Tightening

Use the included hex key to tighten the screws highlighted on the following graphics.

Your scooter motor creates vibrations when you ride it, which may cause the screws on your scooter to loosen over time. We recommend checking your screws every few months to make sure they remain tight. You can use a medium strength headlocker adhesive to further improve their stability.



1 First, fold down the stem of the scooter.

2 Locate and remove the two screws shown above by turning them counter-clockwise using a 5mm allen wrench.

3 Once the folding latch has been removed you will then have access to the main direction bolt. Ensure that this bolt is properly torqued to the recommended 50NM.

4 Proceed to reassemble the folding latch and ensure that the two screws are torqued to 25NM.

SCREW CHART

APOLLO PHANTOM





















TOOL LIST

Allen keys	1x
Manual	1x
Velve Extender	1x
Wrench for motor nut	1x



SCREW LIST

	Size	Grade	Torque	
Fender bracket	ST3.5 x 10	8.8		
Front Cover/Front plate/Rear Covers/Rear plate	M4 x 8	8.8		
Front Cover/Front plate/Rear Covers/Rear plate	M4 x 10	8.8		
Folding hook/Side Plastic covers	M4 x 6	8.8		
Brake lock screw	M6 x 16	10.9		
Throttle screw	M4 x 12	8.8		
Top plate	M5 x 10	8.8		
Display to bracket screw/Kickstand/brake handles	M5 x 16	8.8		
Rocker arm and brake/Handlebar Block	M5 x 20	8.8		
Front locking screw	M5 x 30	12.9		
Front set screw	M5 x 16	12.9		
Under body controller screws	M6 x 12	12.9		
Folding mechanism front tube/Underside Front Screws	M6 x 20	10.9	25 N.m	
Main direction bolt M12	M12 x 45	12.9	50 N.m	
Main direction bolt M14	M14 x 45	12.9	50 N.m	
Main direction washer M12	M12			
Main direction washer M14	M14			
Front and rear wheel nut	M14 x 1.5		25 N.m	

Screw number	Screw use/location	Size	Qty.
1	Fender bracket	ST3.5 x 10	1
2	Front Cover/Front plate/Rear Covers/Rear plate	M4 x 8	1
3	Front Cover/Front plate/Rear Covers/Rear plate	M4 x 10	1
4	Folding hook/Side Plastic covers	M4 x 6	1
5	Hydraulic brake lock screw	M6 x 16	1
6	Throttle screw	M4 x 12	1
7	Top plate	M5 x 10	2
8	Display to bracket screw/Kickstand/brake handles	M5 x 16	1
9	Rocker arm and brake/Handlebar Block	M5 x 20	1
10	Front locking screw	M5 x 30	1
11	Front set screw	M5 x 16	1
12	Under body controller screws	M6 x 12	2
13	Folding mechanism front tube/Underside Front Screws	M6 x 20	1
14	Main direction bolt M12	M12 x 45	1
15	Main direction bolt M14	M14 x 45	1
16	Main direction washer M12	M12	1
17	Main direction washer M14	M14	1
18	Front and rear wheel nut	M14 x 1.5	1



Screw number	Screw use/location	Size	Qty.
1	Fender bracket	ST3.5 x 10	1
2	Front Cover/Front plate/Rear Covers/Rear plate	M4 x 8	1
3	Front Cover/Front plate/Rear Covers/Rear plate	M4 x 10	1
4	Folding hook/Side Plastic covers	M4 x 6	1
5	Hydraulic brake lock screw	M6 x 16	1
6	Throttle screw	M4 x 12	1
7	Top plate	M5 x 10	2
8	Display to bracket screw/Kickstand/brake handles	M5 x 16	1
9	Rocker arm and brake/Handlebar Block	M5 x 20	1
10	Front locking screw	M5 x 30	1
11	Front set screw	M5 x 16	1
12	Under body controller screws	M6 x 12	2
13	Folding mechanism front tube/Underside Front	M6 x 20	1
14	Main direction bolt M12	M12 x 45	1
15	Main direction bolt M14	M14 x 45	1
16	Main direction bolt M12	M12	1
17	Main direction washer M14	M14	1
18	Front and rear wheel nut	M14 x 1.5	1



Maintenance Table

	5km / every ride	50km	500km	1000km
Tires	Check tire pressure	X	X	Change tire
Brakes	Ensure that the brakes are functional	Ensure that brakes are properly adjusted	Lubricate brake cables (Mechanical brakes)	Change brake pads
Lights	Ensure that all the lights work properly	X	X	X
Suspension	X	Ensure that the front and rear suspension are properly tightened	Grease the suspension pin	Perform a full inspection of the suspension. Change the suspension at the slightest sign of wear.
Locking mechanism	Ensure that the locking mechanism is tight	Re-tension the locking mechanism	X	X
B attery	X	X	Review Battery health (only) Refer to the app	X
Handlebar components	Ensure that all the handlebar components are properly tightened	X	X	X
Direction / bearings	Ensure no looseness in the steering system	X	X	X
Wheel nut	X	Ensure that the wheel nuts are properly tightened	X	X
Motor bolt	X	X	Ensure that the motor bolts are properly tightened	X
Headset screws	X	Ensure that the headset is properly fastened	X	X
Main direction bolt	X	X	Ensure that the main direction bolt is at the correct torque (40Nm – 50Nm)	Change the main direction bolt once a year or 1000km (whichever comes first)
Fender screws	X	X	Ensure that the fender screws are not coming loose	X

TROUBLESHOOTING

Error codes

Your scooter comes with a built-in communication system that allows for quicker diagnosis of common issues. Please consult the next table for a classification of codes.

Please note

For full troubleshooting video library, visit our Servicing & Support Center.



E1

F1

BRAKE ERROR

F1 is reported when the power-on brake self-test fails.
E1 is reported when a brake error occurs during operation.

Solutions:

Ensure that the brake switch and the regen throttles are properly connected.

Replace the brake switch, if the error code goes away, the switch/brake handle was faulty.

If the problem persists, check whether the switch-to-insertion sequence and the output voltage of the switch Hall are abnormal.

E2

F2

THROTTLE FAILURE

F2 is reported when the power-on throttle self-test fails.
E2 is reported when a throttle error occurs during operation.

Solutions:

Ensure that the throttle connector is properly connected.

Replace the throttle switch, if the error code goes away, the throttle was faulty.

If the problem persists, check whether the switch-to-insertion sequence and the output voltage of the switch Hall are abnormal.

E3

COMMUNICATION FAILURE

The controller to display communication is not working properly.

Solution:

Replace the communication cable between the display and the controller. If the error is fixed, the connection line is short-circuited or broken, and it can be replaced.

If the error is still reported, it is considered to be a hardware failure of the display or controller.

If the error persists the display or the controller will need to be replaced.

Failure displays / Error Codes

If a malfunction occurs while using your Apollo Phantom , then one of the following failure display codes will appear on the screen:

E4

OVER CURRENT PROTECTION

If the E4 fault continues to be reported, the controller is broken and should be replaced.

E5

UNDER VOLTAGE PROTECTION

Battery voltage is under the recommended level.

Solution:

Check whether the battery voltage is too low.

Try charging the scooter, if the problem persist replace the battery with a new one to test if the fault is eliminated.

E6

OVER VOLTAGE PROTECTION

Battery level is over the recommended level.

Solution 1:

Avoid sudden braking at this time, the battery level will come down to recommended levels after use.

Confirm that the voltage output of your charger is not over the recommended voltage.

E7

MOTOR ERROR

There is a problem with the motor.

Solution:

Check whether the wiring of the motor is loose. Make sure everything is connected properly.

If the wiring is properly connected and an error is still reported, the Hall of the motor is damaged and the motor needs to be replaced.

E9

CONTROLLER ERROR

The controller might be faulty.

Solution:

Try turning on and off 5 times.

If the problem persists the controller needs to be replaced.

NOTE:

Visit our Servicing & Support Center for a troubleshooting guide and instructions on how to replace parts or contact us directly via our Support Page.

WARRANTY & SERVICES

Warranty Structure

All Apollo Scooters are covered with a 12-Month Limited Warranty. For more details about the warranty scan the QR code below.



Apollo Plus

Apollo Plus is a suite of services that will support our customers along every facet of scooter ownership. Apollo Plus provides peace of mind services to protect your orders while shipping, guarantee they are operating at the highest standard, and ensures you are back to riding as quickly as possible in case something goes wrong.

FCC compliance statement

This device complies with part 15 of the FCC Rules.
Operation is subject to the following two conditions:

- (1) This device may not cause harmful interference, and
- (2) this device must accept any interference received, including interference that may cause undesired operation.

Note: This equipment has been tested and found to comply with the limits for a Class B digital device, pursuant to Part 15 of the FCC Rules. These limits are designed to provide reasonable protection against harmful interference in a residential installation. This equipment generates, uses and can radiate radio frequency energy and, if not installed and used in accordance with the instructions, may cause harmful interference to radio communications.

However, there is no guarantee that interference will not occur in a particular installation. If this equipment does cause harmful interference to radio or television reception, which can be determined by turning the equipment off and on, the user is encouraged to try to correct the interference by one or more of the following measures:

- Reorient or relocate the receiving antenna.
- Increase the separation between the equipment and receiver.
- Connect the equipment into an outlet on a circuit different from that to which the receiver is connected.
- Consult the dealer or an experienced radio/TV technician for help.

Warning: Changes or modifications to this unit not expressly approved by the part responsible for compliance could void the user's authority to operate the equipment.

FCC RADIATION EXPOSURE STATEMENT

The device has been evaluated to meet general RF exposure requirement.
The device can be used in mobile (min20cm) exposure condition.

IC Statement:

This device complies with Canada Industry licence-exempt RSS standard(s).
Operation is subject to the following two conditions:

- (1) this device may not cause interference; and
- (2) this device must accept any interference. Including interference that may cause undesired operation of the device.

AVIS D'INDUSTRIE CANADA

Le présent appareil est conforme aux CNR d'industrie Canada applicables aux appareils radio exempts de licence L'exploitation est autorisée aux deux conditions suivantes:

- 1) l'appareil ne doit pas produire de brouillage; et
- 2) l'utilisateur de l'appareil doit accepter le brouillage radioélectrique subi même si le brouillage est susceptible d'en compromettre le fonctionnement. mauvais fonctionnement de l'appareil.

CAN ICES-3 (B)/ CAN NMB-3 (B)

Radiation Exposure Statement:

This equipment complies with IC radiation exposure limits set forth for an uncontrolled environment. This equipment should be installed and operated with minimum distance 20cm between the radiator & your body.

Déclaration d'exposition aux radiations:

Cet équipement est conforme aux limites d'exposition aux rayonnements IC établies pour un environnement non contrôlé. Cet équipement doit être installé et utilisé avec un minimum de 20 cm de distance entre la source de rayonnement et votre corps.



**We hope you enjoy your Apollo
Phantom Scooter as much as we
loved developing it!**

If you want to stay connected with us and learn all about our
future innovations, you can follow us on:



@APOLLO SCOOTERS



@RIDEAPOLLO



APOLLO SCOOTERS



@RIDEAPOLLO

USA

apolloscooters.co

CANADA

apolloscooters.ca